

## GENERAL DESCRIPTION

The PEB 8024 is a half-bridge power module featuring two Silicon Carbide (SiC) MOSFETs. It is designed for use as a building block for power electronic converters.

Direct access to the gating signals is offered using optical fiber inputs, while galvanically-isolated on-board sensors provide analog measurements related to the DC voltage and the AC output current. The modules also provide on-board protections against over-current, over-voltage and over-temperature.

As with all imperix power modules, PEB 8024 are compatible for plug-&-play connection to the imperix programmable controller [B-Box RCP](#), but can also be used with other digital controllers.

The mechanical design of the modules is tailored for integration in 19" rack-mountable chassis and enclosures.

## TYPICAL APPLICATIONS

Imperix modules are perfectly suited to build up ambitious power converter prototypes of any topology, ranging from single- and three-phase inverters to more complex multilevel topologies.

Thanks to their ultra-fast switching characteristics and ultra-low switching losses, PEB 8024 modules are best implemented within high-performance and fast switching converters. They can notably be used in medium-frequency, hard-switched applications up to 200kHz.

Typical applications include:

- » Isolated DC/DC converters
- » Medium-frequency converters
- » Active filters
- » Power amplifiers and emulators
- » High-performance / high-speed drives

## KEY FEATURES AND SPECIFICATIONS

- » Half-bridge topology (SiC phase-leg)
- » Embedded 235 µF DC bus
- » On-board voltage and current sensors
- » Over voltage/current/temperature protections
- » 1200V/36 A SiC MOSFETs
- » 800V nominal DC bus voltage
- » 24 A continuous RMS current at 20 kHz
- » 80 A max pulsed current
- » Speed-regulated cooling (140W TDP)
- » Up to 200 kHz switching frequency
- » 100x332 mm Eurocard form factor

## SIMILAR PRODUCTS

Other types of half-bridge modules are available from imperix, with different voltage and current ratings as well as different semiconductor technologies:

- » [PEB 8038](#) – 800V/38 A – Higher power
- » [PEB 800-40](#) – 800V/40 A – All-rounder
- » [PEB 4050](#) – 400V/50 A – Higher current

Other topologies such as full-bridge modules and 3-level NPC modules are also available.

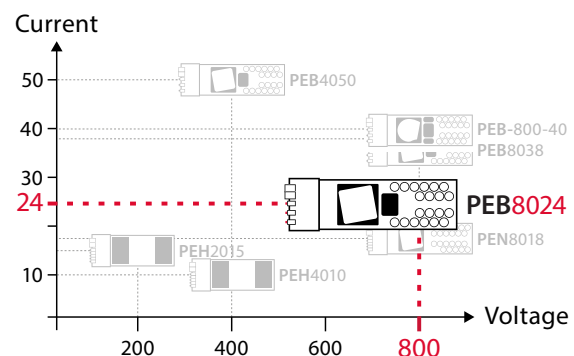

## DEVICE DESCRIPTION

The power module is a ready-to-use power electronic building block based on the elementary phase-leg arrangement of two power semiconductors. It embeds all the necessary circuits for simple and proper operation.

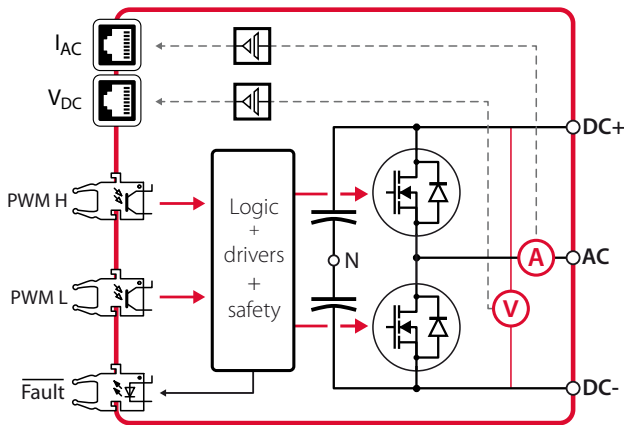

Fig. 1. Schematic overview of the PEB 8024 module

## TYPICAL APPLICATION

An elementary application of the PEB 8024 power module is shown in Fig. 2. The implemented system corresponds to a DC/DC converter in buck configuration, also known as DC chopper.<sup>1</sup> This system produces a controllable voltage on the resistive load  $R$ , thanks to suitable PWM signals applied at the input of the power module. If desired, feedback control can be implemented in order to improve the stability and/or dynamic performance of the output current, voltage or power.

Thanks to the rapid implementation of power modules, experimental validation on power electronic applications and their control can be facilitated and accelerated.

In most use cases, several modules are assembled in order to form various power converter topologies. An external power electronic controller, such as the B-Box RCP, in order to generate the necessary PWM signals.

### Power connections

- » DC bus terminals (DC+ and DC-)
- » Switching midpoint (AC terminal)
- » DC bus midpoint (N, optional connection)

### Signal connections

- » PWM signals inputs (650 nm optical fiber receivers)
- » AC current measurement (analog output, RJ45)
- » DC voltage measurement (analog output, RJ45)
- » Fault feedback signal (650 nm optical fiber emitter)

### Auxiliary connections

- » 5/12V power supply (local control and cooling fan)
- » Module-to-module coordination cable (optional)

In order to build a complete power electronic system, several accessory products may be required, such as:

- » A [mounting solution](#) (e.g. rack-mountable chassis)
- » An auxiliary power supply (e.g. from the chassis)
- » A PWM signals generator, or better, a fully-programmable digital controller such as the [B-Box RCP](#);
- » External current and/voltage [sensors](#) (optional);
- » Passive components, such as inductors or [filters](#);
- » Power sources (e.g. laboratory supply, batteries, grid)
- » Electric load (e.g. resistors or regenerative loads)
- » Laboratory instruments (e.g. meters, probes)

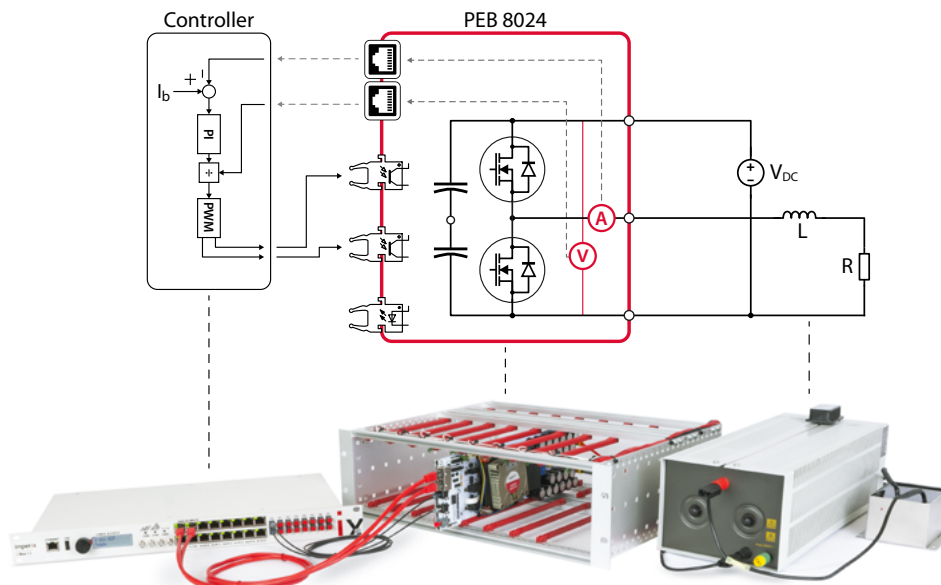

Fig. 2. Topology of a buck converter using the power module

<sup>1</sup> This example and many more are available on the [imperix knowledge base](#).

## ABSOLUTE MAXIMUM RATINGS

Parameter	Symbol	Test conditions	Max.	Unit
Maximum DC bus voltage	$V_{DC,max}$	Power module not switching	850	V
Maximum repetitive isolation voltage	$V_{IORM}$		1.4	kV <sub>PEAK</sub>
Maximum transient isolation voltage (1 s)	$V_{IOTM}$		3.0	kV <sub>PEAK</sub>
Highest allowable junction temperature	$T_{J(max)}$		150	°C
Continuous total power dissipation	$P_{cooler,max}$		140	W
Maximum auxiliary voltage (5V power supply)	$V_{5V,max}$		5.5	V
Maximum auxiliary voltage (12V power supply)	$V_{12V,max}$		13.2	V
Storage temperature	$T_{stor}$		50	°C

## MODULE RATINGS

Parameter	Symbol	Test conditions	Min.	Typ.	Max.	Unit
DC bus voltage <sup>1</sup>	$V_{DC}$		0	800	850	V
Maximum continuous leg current <sup>2</sup>	$I_{leg,max}$	$T_c = 100^\circ\text{C}$ , $f_{sw} = 20\text{kHz}$ Reverse conduction in the channel <sup>4</sup>	-	24	-	A <sub>RMS</sub>
Maximum pulsed leg current	$I_{leg,pulsed}$	Pulse width limited by $T_{J(max)}$	-	80	-	A <sub>RMS</sub>
Maximum DC bus ripple current <sup>3</sup>	$I_{RIPPLE}$	$f = 120\text{Hz}$	-	4.7	-	A <sub>RMS</sub>
		$f = 100\text{kHz}$	-	13.2	-	A <sub>RMS</sub>

### Derating curves

Depending on the real operating conditions, the average RMS current that can be handled by the power module may vary. Derating must notably be applied in the following cases:

- » The switching frequency is increased (Fig. 3)
  - » The average duty-cycle deviates from 50% (Fig. 4)
- Reciprocally, the current capability can be increased in the following cases:
- » The DC bus voltage is reduced (Fig. 5)
  - » Soft-switching is made possible by external components and circuit conditions (see related literature)
- Additionally, further derating due to the ambient air temperature or other environmental conditions may apply.

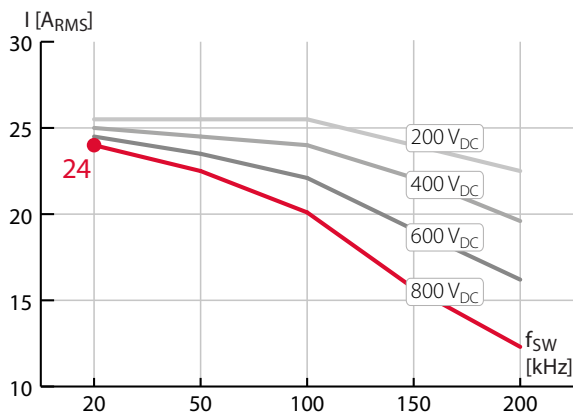

Fig. 3. Current capability as a function of the switching frequency

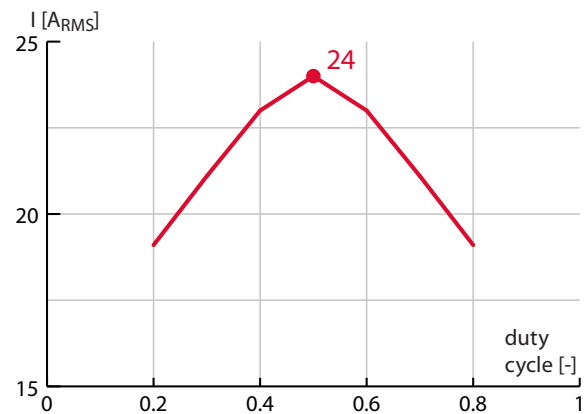

Fig. 4. Current capability as a function of the average duty-cycle

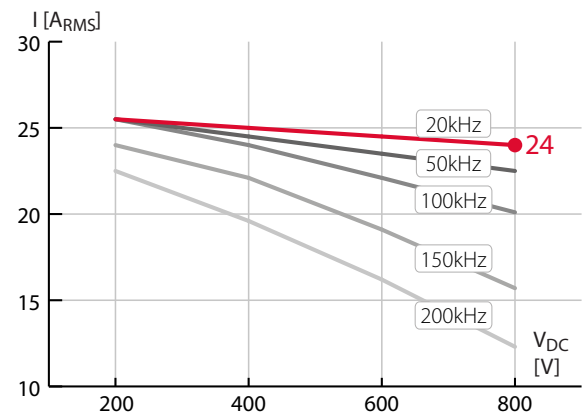

Fig. 5. Current capability as a function of the DC-bus voltage

<sup>1</sup> The maximum DC bus voltage is defined by the specifications of the bus capacitors. Therefore, as for any aluminum electrolytic capacitors, few short-term over-voltages can be tolerated, provided that they involve limited amounts of energy.

<sup>2</sup> In cold conditions, the maximum current is limited by the power semiconductors. Otherwise, the current rating of the module is limited by the power envelope of the cooler (about 140W with airflow).

<sup>3</sup> The maximum ripple current is defined by the equivalent series resistance (ESR) of the capacitors and relates to Joule losses and lifetime considerations. Therefore, this value can be temporarily exceeded, provided that the operating temperature of the capacitors remains low.

<sup>4</sup> This indicates that both switches are actively used and that reverse conduction inside the MOSFET channel is used in order to reduce the conduction losses.

## MAIN COMPONENTS

Component	Devices	Main specifications
Power switches	2x Cree C2M0080120D	SiC MOSFET – See below or device datasheet
Capacitors	1x 235uF @ 800V (2 banks of 10x47uF each)	
Drivers	2x Texas Instruments ISO5452-Q1	2.5 A, 100 kV/μs, $V_{IORM} = 1.42 kV_{PEAK}$ , $V_{IOTM} = 8 kV_{PEAK}$
Isolated DC/DC Converters	2x Murata MGJ2D122005SC	12 V to 20/-5V, 2 W, $V_{ISO} = 5.2 kVDC$
	1x Recom RK-0505S	5 V to 5 V, 1 W, $V_{ISO} = 3 kVDC$
Current sensor	1x LEM LKSR50-NP	
Voltage sensor	1x Resistive divider + TI AMC1311B	
Cooler	1x Dynatron G199	0.33 °C/W @ full speed

## EMBEDDED SENSORS

### Current measurement circuit

Parameter	Symbol	Note	Min.	Typ.	Max.	Unit
Nominal measured current	$I_{PN}$		-	±50	-	Arms
Measuring range <sup>4</sup>	$I_{PM}$		-	±75	-	A
Nominal sensitivity	G	Including a x2 gain on the Mezzanine	-	50.0	-	mV/A
Sensitivity error <sup>5</sup>	X		-	-	1.1	%
Bandwidth	$f_{3dB}$		-	280	-	kHz
	$f_{1dB}$		-	200	-	kHz
Measurable slope	dI/dt		-	50	-	A/μs

### Voltage measurement circuit

Parameter	Symbol	Note	Min.	Typ.	Max.	Unit
Measuring range	$V_{OPT}$		0.0	-	800	V
Maximum measuring range <sup>4</sup>	$V_{FS}$		0.0	-	980	V
Nominal sensitivity	G	Including a x2 gain on the Mezzanine	-	4.99	-	mV/V
Uncalibrated sensitivity error	$G_{ERR}$	25° to 125 °C, including resistive divider		±2.0		%
Gain error over temperature	$G_{ERR,t}$	$T_A = 25°$ to 100 °C		±0.1		%
Bandwidth	$f_{3dB}$		-	8.0	-	kHz
Measurable slope	dV/dt		-	170	-	V/μs
Maximum working isolation voltage	$V_{IORM}$		-	1140	-	$V_{DC}$

## RECOMMENDED B-BOX RCP CONFIGURATION

### Dead time

The proper selection of the dead time is crucial to guarantee the safe operation of the power module. The dead time must be sufficiently long to avoid the simultaneous conduction of both semiconductors (shoot-through), and sufficiently short as to avoid excessive distortion. More information is provided in the related [technical note](#).

Parameter	Symbol	Note	Min.	Typ.	Max.	Unit
Dead time	DT		100	150	-	ns

### Measurement sensors

For optimal measurements, the following parameters are recommended for use with the B-Box RCP. The values of hardware protection thresholds may be reduced according to the desired operating conditions.

Measurement	Sensitivity	Example operating range	Front-end Gain	Front-end Low-Z	Front-end thresholds
Voltage	4.99mV/V	[-10V; +820V]	2.0	No	[-0.1 V; +8.2 V]
Current	50.0 mV/A	[-30A; +30A]	4.0	No	[-6.0V; +6.0V]

<sup>4</sup> The current and voltage measurements are isolated on-board. The measured values are available as differential signals on the mezzanine connectors, with voltages ranging in the interval between 0 and 3.3V.

<sup>5</sup> When calibrated under stabilized operating temperature conditions, superior performance can be achieved.

## POWER SEMICONDUCTORS

Parameter	Symbol	Test conditions	Min.	Typ.	Max.	Unit
MOSFET drain-source on-state resistance	$R_{DS(on)}$	$I_{DS} = 24\text{ A}, T_j = 25^\circ\text{C}$	-	80	95	$m\Omega$
		$I_{DS} = 24\text{ A}, T_j = 150^\circ\text{C}$	-	145	170	$m\Omega$
Diode forward voltage	$V_F$	$I_{SD} = 24\text{ A}, T_j = 150^\circ\text{C}$	-	4.6	-	V
Peak reverse recovery current	$I_{RRM}$	$I_{SD} = 24\text{ A}, V_R = 800\text{ V}, V_{GS} = -5\text{ V}$	-	12	-	A
Reverse recovery delay	$t_{RR}$		-	28	-	ns
Thermal resistance junction-to-case	$R_{thJC}$		-	0.6	0.65	$^\circ\text{C}/\text{W}$
Turn-on losses (inductive load)	$E_{on}$	$I_D = 24\text{ A}, V_{DS} = 800\text{ V}, R_{g(ext)} = 2.5\ \Omega$	-	640	-	$\mu\text{J}$
Turn-off losses (inductive load)	$E_{off}$	$V_{GS} = -5/20\text{ V}, L = 156\ \mu\text{H}, T_j = 150^\circ\text{C}$	-	130	-	$\mu\text{J}$
External gate resistance	$R_g$		-	2.5	-	$\Omega$

## MEZZANINE BOARD

The mezzanine board provides access to the measurements (analog outputs) as well as the gating signals (optical inputs). Additionally, the error signal is also relayed through an optical output.

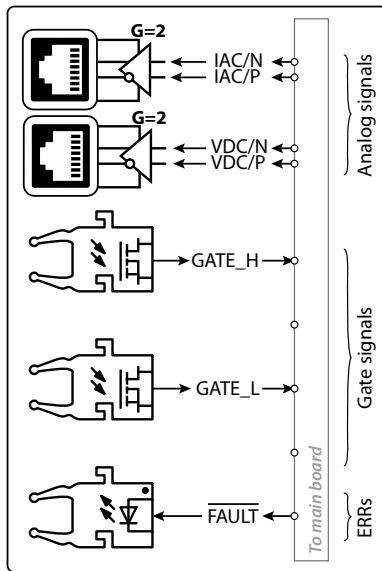

Fig. 6. Functional view of the mezzanine.

## Optical fiber inputs

The optical receivers are meant to receive the gating signals (PWM). They can be interfaced with standard Plastic Optical Fibers (POF) or Plastic Clad Silica (PCS) fibers. A product reference example is given on page 11.

Parameter	Symbol	Test conditions	Min.	Typ.	Max.	Unit
Analog power supply voltage	$V_{PS}$		$\pm 11$	$\pm 15$	$\pm 18$	V
Analog power supply current	$I_{PS}$				100	mA
Maximum measurement output voltage	$V_{out}$		-	$\pm 3.4$	-	V
Optical receivers sensitivity range	$\lambda_R$		400	-	900	nm
Optical receivers power high	$P_H$	$\lambda_R$ between 635 and 680nm	-22	-	+2	dBm
Optical receivers power low	$P_L$	$\lambda_R$ between 635 and 680nm	-	-	-40	dBm
Optical emitter emission wavelength	$\lambda_C$		640	650	680	nm
Optical emitter output power	$P_{High}$		-6	-	+2	dBm

## Analog outputs

The two analog outputs (voltage and current sensors) use standard RJ45 sockets. Each channel is driven by a full-differential amplifier, which requires an external  $\pm 15\text{V}$  power supply. The pinout is shown below.

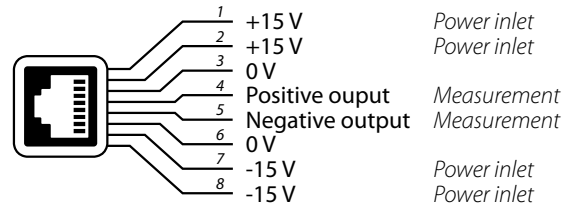

## Mezzanine connectors

Two connectors provide the necessary signals for sharing the fault status information among different power modules. Their pinout is given below.

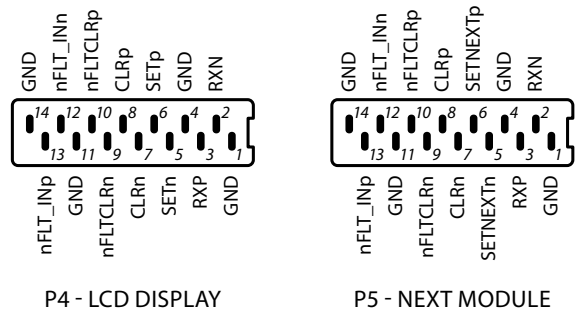

## POWER SUPPLY

The module requires 5V and 12V power supplies:

- » The 5V is used by on-board logic as well as for the integrated sensors.
- » The 12V is used by the cooler as well as for powering the gate drivers.

The connector is a 2.54mm three-position header (e.g. MTA-100 series from TE Connectivity). The pinout is indicated in the following figure.



Parameter	Symbol	Min.	Typ.	Max.	Unit
5V PSU voltage	$V_{5V}$	4.7	5.0	5.3	V
5V PSU current	$I_{5V}$	-	-	300	mA
12V PSU voltage	$V_{12V}$	10.8	12	13.2	V
12V PSU current	$I_{12V}$	22	-	820	mA

## EMBEDDED LOGIC AND PROTECTION

### Main components

The module embeds a digital supervisory system that guarantees its integrity by a continuous monitoring of on-board measurements (current and voltage), as well as the cooler temperature, fan speed and power supply voltages. The main components are as follows:

- » **MCU1** is continuously sampling the voltage and current at approximately 150 kbps. Upon the detection of an overvalue, the MCU triggers the associated flag.
- » **MCU2** is continuously sampling slow variables such as the cooler temperature and power supply voltage. Upon the detection of an overvalue, the MCU triggers the corresponding error flag.
- » The **CPLD** is at the heart of the protection logic and has three main tasks:
  - » Generating the final gating signals based on those received through the optical fibers.
  - » Enforcing a blocked state in case of a fault.
  - » Generating a set of flags based on the faults provided by the micro-controllers.

### Configuration

The safety thresholds are defined as follows:

Event	Flag	Fault-triggering when
Over-voltage	VOLT	$V_{DC} > 850V$
Over-current	CURR	$ I_A  > 40A$
Desaturation	DESAT	$V_{DS} > 6.2V$ on either switch during 'on' state (corresp. to $I_D > 60A$ ) OR a shoot-through
Bad 5V power supply	PSUP	$V_{5V} < 4.5V$ or $V_{5V} > 5.5V$
Bad 12V power supply		$V_{12V} < 11V$ or $V_{12V} > 13V$
Over-temperature	TFAN	$T > 80^\circ C$
Fan error		Fan speed < 600 rpm (no fan connected)

All the above-mentioned faults are combined into a single fault signal which, deactivates the gating signals in case of fault.

When a fault is detected, it is automatically cleared after a power-cycle of the module or when the clear button, located on the mezzanine, is pressed. If the fault is still present, the module will stay in fault state.

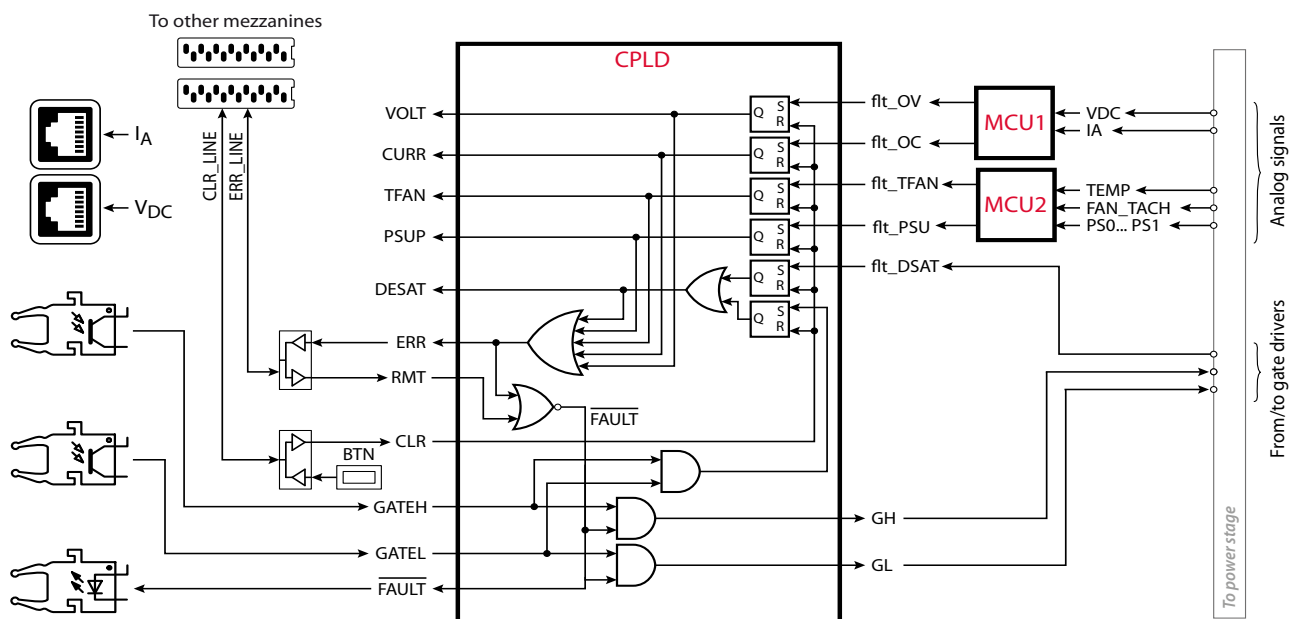

Fig. 7. On-board protection and logic circuits

## Fault signal sharing

In multi-modules arrangements, it may be useful to share the fault signal among the complete system in order to safely shut down the converter in case of fault. This can be done using the 14-pin connector of the mezzanine and daisy-chaining the connection, as shown in Fig. 8:

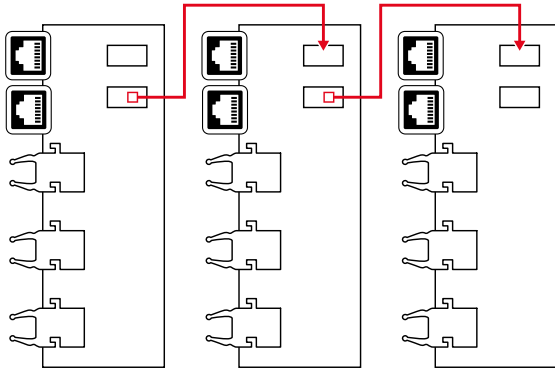

Fig. 8. Fault signal sharing among several modules

The clear signal is also shared between all power modules. This means that a fault can be cleared by pressing the clear button on any of the mezzanines.

## TYPICAL APPLICATIONS

Most power converter topologies can be built using half-bridges, which can be considered as the basic building blocks of virtually all power electronic systems. Several basic use case scenarios are shown below.

### Single-phase PV inverter with boost

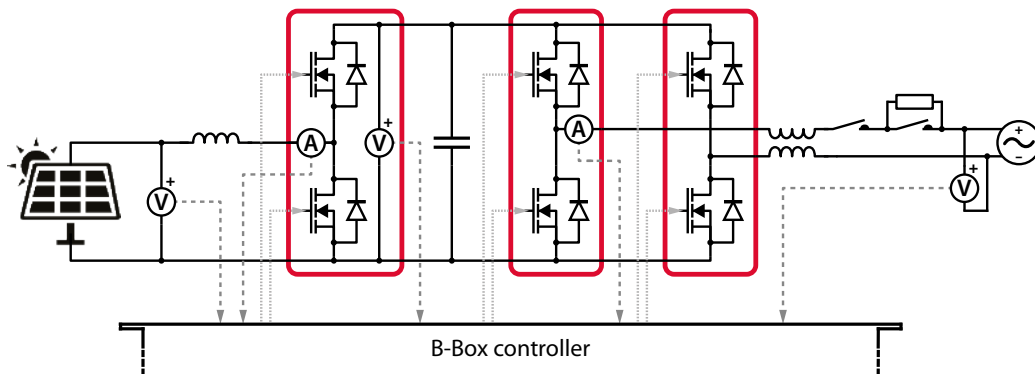

Fig. 9. Single-phase inverter with PV boost

A photovoltaic panel or string can be connected to the electric grid using three PEB 8024 modules (Fig. 9). The first module is used as a boost-type DC/DC converter in order to raise the voltage to a sufficient DC bus level. The two other modules are used as a single-phase inverter. Two external voltage sensors are required, in order to retrieve the PV and grid voltages.

On the control side, a Maximum Power Point Tracking (MPPT) algorithm is typically implemented on top of current control for the boost. Multiple techniques exist for the control of the single-phase inverter. More information can be found on the dedicated [application note](#).

## Fault status LEDs

Six red LEDs are present on the front side of the module, under the mezzanine, indicating the origin of the fault, when applicable. After pressing the clear button, all fault status LEDs shall switch off, provided that the fault condition has disappeared.

N°	Text	Description
1	VOLT.	Over-voltage detected on the DC bus
2	CURR.	Over-current detected on the switching point (AC)
3	DESAT.	Excessive drain-source voltage during on-state
4	P.SUP.	Inadequate power supply voltage
5	T.FAN	Over-temperature on the cooler or fan fault
6	RMT	Remote fault flag active (triggered remotely or locally)

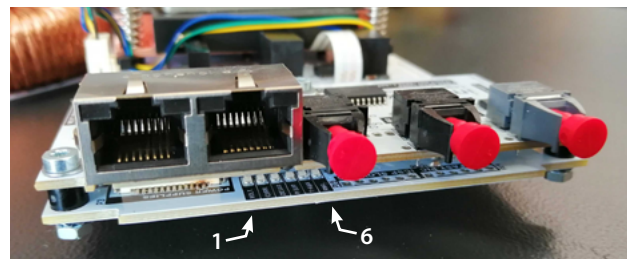

Description	Quantity	Proposed product
Phase-leg power modules	3	imperix PEB 8024
Real-time control platform	1	imperix B-Box RCP
Open chassis for modules	1	imperix 3U Open Rack type A
External voltage sensors	2	imperix DIN800V
Optical fibers	6	Firecomms FD-02MBSB
Analog RJ45 cables	5	Roline 21.15.0341
Inductors	3	Hahn V23105
Precharge circuit	1	imperix GSP 230V 12A
PV panel / DC source	1	-
Grid connection / AC load	1	-
Wires for power connections	x	-

## Dual-Active Bridge converter (DAB)

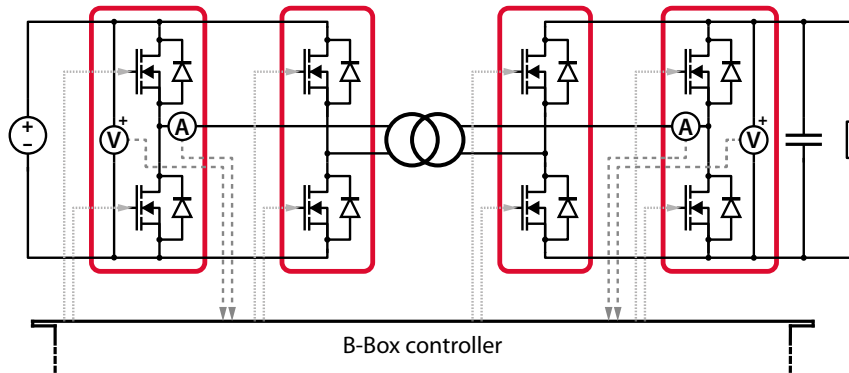

Fig. 10. Dual-Active Bridge converter

This topology is a DC/DC converter offering galvanic isolation and bidirectional power flow (Fig. 10). The galvanic isolation between the primary and the secondary is ensured by a medium- or high-frequency intermediary transformer.

Various modulation techniques can be used with this topology, some of them are described in the corresponding [technical note](#). This topology can be modified to extend the number of ports, such as described in the [Triple-Active Bridge](#) application.

Description	Quantity	Proposed product
Phase-leg power modules	4	imperix PEB 8024
Real-time control platform	1	imperix B-Box RCP
Open chassis for modules	1	imperix 3U Open Rack type A
Optical fibers	8	Firecomms FD-02MBSB
Analog RJ45 cables	4	Roline 21.15.0341
MF transformer	1	-
DC source	1	-
Resistive load	1	-
Wires for power connections	x	-

## Variable-speed motor drive

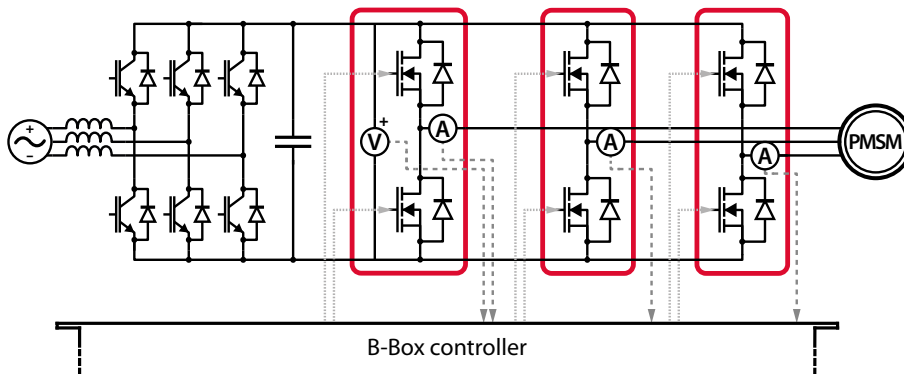

Fig. 11. Three-phase variable-speed electric motor drive

Variable-speed drives are used for different types of motors, such as the Permanent Magnet Synchronous Machines (PMSM), which are typically used in the electrical cars or with wind turbines. Three PEB 8024 power modules are needed to implement the motor-side inverter. Various control approaches and modulation techniques can be used for this type of electric machines. The corresponding [application note](#) describes a typical control algorithm for this setup.

In laboratory applications, another electric machine can also be connected to the shaft of the PMSM in order to produce a fully-controllable torque, emulating the load conditions that the motor is subject to.

Description	Quantity	Proposed product
Phase-leg power modules	3	imperix PEB 8024
Real-time control platform	1	imperix B-Box RCP
Open chassis for modules	1	imperix 3U Open Rack type A
Optical fibers	6	Firecomms FD-02MBSB
Analog RJ45 cables	4	Roline Red 21.15.0341
PMSM	1	-
Grid rectifier / DC source	1	-
Wires for power connections	-	-

## THERMAL CONSIDERATIONS

### Mechanical assembly

Both MOSFET semiconductors use a TO-247 package, directly mounted onto an aluminum mounting bracket, which simultaneously provides electric isolation and excellent thermal conduction.

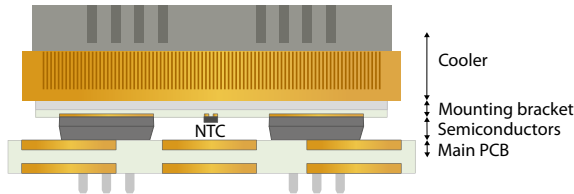

Fig. 12. Cross-section view of the power modules (the dimensions are not corrects for the purpose of illustration)

A NTC thermistor is also located on the mounting bracket, connected to the main board with a small flat cable. This way, the supervisory logic can trigger a fault in case of over-temperature.

### Thermal modeling

A rudimentary thermal model of the power module is proposed in Fig. 13. This model is a stabilized temperature model, meaning that thermal inertia of the lumped elements is not taken into account.

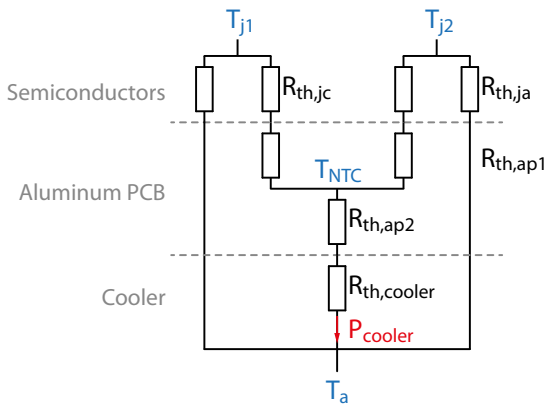

Fig. 13. Thermal model of the power module (steady-state).

## CHARACTERIZATION TEST SETUP

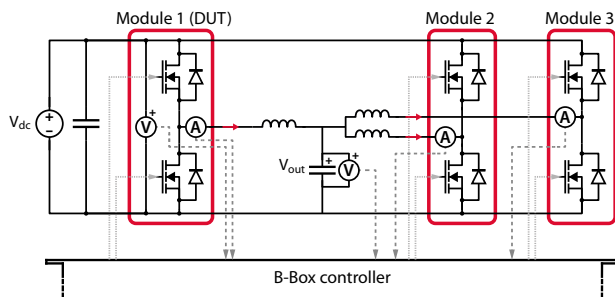

Fig. 15. Topology used to determine the ratings of the power module

Name	Description	Value	Unit
$T_{j1}, T_{j2}$	MOSFETs junction temperature	-	°C
$T_{NTC}$	NTC temperature	-	°C
$T_a$	Cooling air temperature	-	°C
$R_{th,jc}$	MOSFET junction to case thermal resistance	0.60	°C/W
$R_{th,ja}$	MOSFET junction to air thermal resistance	40	°C/W
$R_{th,ap1}$	Mounting bracket thermal resistance 1	0.41	°C/W
$R_{th,ap2}$	Mounting bracket thermal resistance 2	0.94	°C/W
$R_{th,cooler}$	Cooler thermal resistance	0.33	°C/W
$R_{th,ipa}$	MOSFET junction to air via pin	15	°C/W

Importantly, the cooling air temperature  $T_a$  designates the air around the cooler, which may be that inside an enclosure rather than room temperature.

From a thermal perspective, the power module ratings are limited by the MOSFETs maximum junction temperature, as well as the maximum power dissipation of the cooler (140W).

At this point of maximum power dissipation, the temperature difference between the ambient air temperature and the NTC temperature is approximately 45°C. The protection threshold is set at 80°C, which means that the power module can be used at its maximum ratings in a closed rack, where the temperature can rise up to 45°C. In a hotter environment, power derating is required according to Fig. 14.

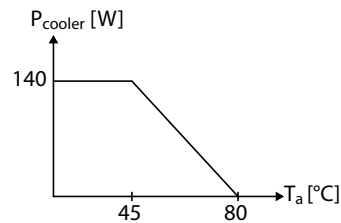

Fig. 14. Power dissipation derating with the ambient temperature.

The test setup used for modules characterization is depicted in Fig. 15.

The device under test (DUT) is used as a chopper, operated with a controllable duty-cycle. This configuration can be used for both AC and DC current conditions. It also minimizes power consumption thanks to recirculation of energy inside the DC power source.

## MECHANICAL DATA

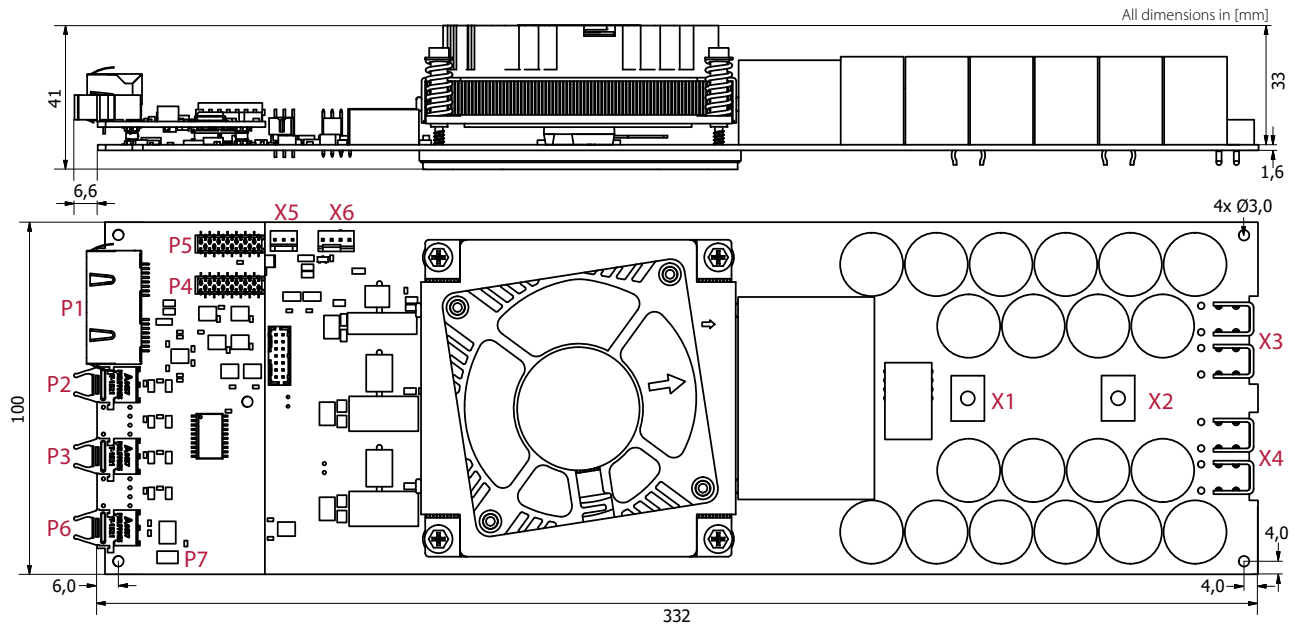

Fig. 16. Dimensional specifications of PEB modules

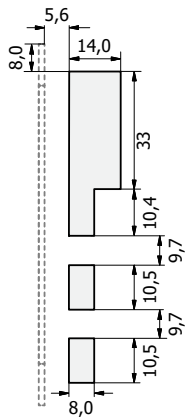

Fig. 17. Recommended front panel cut out

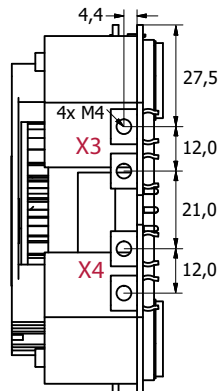

Fig. 18. DC bus power terminals

Label	Role
P1	RJ45 connector for measurements
P2	Gate H optical receiver
P3	Gate L optical receiver
P4	Mezzanine to controller connector
P5	Mezzanine to next mezzanine connector
P6	Global error optical emitter
P7	Clear fault button
X1	AC power terminal
X2	DC midpoint terminal
X3	DC+ power terminal
X4	DC- power terminal
X5	Auxiliary 5V+12V power supply connector
X6	Fan connector

## RELATED PRODUCTS AND ACCESSORIES

### B-Box RCP

The B-Box RCP is a rapid control prototyping (RCP) system that is easily programmable and supports real-time monitoring and debugging. Detailed specifications can be found on the [website](#).



### Open/closed racks

Imperix power modules can be easily assembled within 19" rack-mountable [enclosures](#). Two approaches are available: open racks for handy and affordable integration and closed racks for sleeker and safer configurations.



### Passive filters box

The [passive filters rack](#) provides easy-to-use and configurable filters for two sets of three-phase connections. It can also be easily reused for other applications, thanks to its independent accesses to the inductors.



## CABLES AND CONNECTORS



### Power connectors

All power connectors (X1 to X4 in Fig. 16) possess M4 threaded holes. It is recommended to use cable shoes and a wire section of at least 4 mm<sup>2</sup>.



### Power supply connector

The power supply inlet uses of a 3-position MTA 100 terminal. A wire section of at least 0.25 mm<sup>2</sup> is recommended.

### External sensors

The external [voltage and current sensors](#) are designed to be easy-to-use along with the B-Box RCP: the power supplies and the measurements are provided in one single RJ45 cable. Sensors can be mounted on standard 35 mm DIN rails.



### Alternative power modules

The full list of imperix power modules and their comparison is available on the [imperix website](#).



### Optical fibers

PWM gating signals must be provided using plastic optical fibers cables with simplex friction plugs. They are available on the [website](#).



### Analog cables

On-board measurements (current and voltage) are accessible with any standard RJ45 cable. Cables are available on the [website](#).



### Mezzanine to mezzanine cable

The fault signal can be shared among several modules using a 14-pin flat cable. The recommended reference is TE Connectivity 2205065-1.

## WARRANTY

According to the Swiss legislation, power modules are guaranteed for 2 years parts and labor, from the date of delivery, excluding damages to power semiconductors. For parts exchanged or repaired during the warranty period, the new warranty period ends at the same time as the original one, or at least six months.

## ROHS COMPLIANCE

The PEB 8024 power module is compliant with the current EU RoHS requirements for all 10 RoHS substances.



**Caution, high risk of electrical shock!**  
**All conducting parts must be inaccessible after installation.**

When using the devices, certain parts may carry hazardous voltages (e.g. power supplies, busbars, etc.).

Power electronic modules must be used in electric / electronic installations with respect to applicable standards and safety requirements. User must operate the devices in accordance with the manufacturer's operating instructions.

Disregarding this warning may lead to severe injury and/or cause serious damage.

## Contact

imperix Ltd.  
Rte des Ronquos 23  
1950 Sion, Switzerland  
phone: +41 27 552 06 60  
fax: +41 27 552 06 69  
www.imperix.com, sales@imperix.ch

## About us

Imperix is a company established in Sion, Switzerland. Its name is derived from the Latin verb *imperare*, which stands for 'controlling' and refers to the company's main business: the control of power electronic systems. Imperix commercializes hardware and software solutions for the fast implementation of prototyping and pilot systems in the fields of power electronics, energy storage, smart grids and related systems.

## Note

While every effort has been made to guarantee the accuracy of this publication, no responsibility can be accepted for any errors or omissions. Data may change, as well as legislation, and the reader is strongly advised to obtain copies of the most recently issued regulations, standards, and guidelines.

This publication is not intended to form the basis of a contract. Copyright 2021. All rights reserved.