

# VHDCI ADAPTER

RCP-VHD

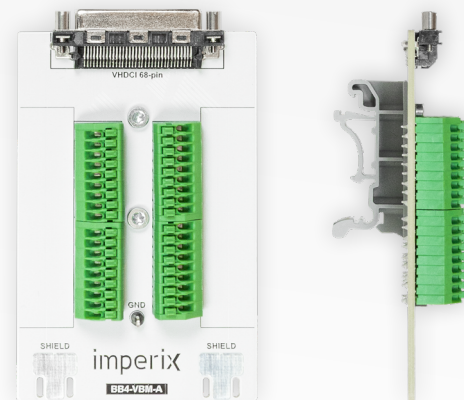
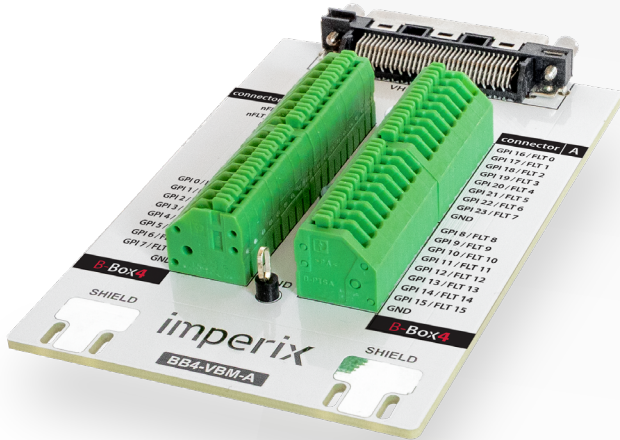

## GENERAL DESCRIPTION

The VHDCI breakout adapter is an interface board designed to provide easy access to the electrical I/O of imperix controllers. It converts the 68 pins of a high-density VHDCI connector into accessible terminals, simplifying the integration of external signals.

## KEY FEATURES

- **Push-in terminals:** Fast and tool-free wiring.
- **Customizable labeling:** Adhesive labels provided to identify terminals according to the controller and the port used (A, B, C or D).
- **DIN rail compatibility:** Easily mounting on 35 mm DIN rails.
- **Shielding:** Dedicated pads under the cable to ensure continuity.

## TECHNICAL SPECIFICATIONS

The VHDCI adapter is fully passive and contains no active component, ensuring bidirectional operation and transparent signal path.

## MECHANICAL DATA

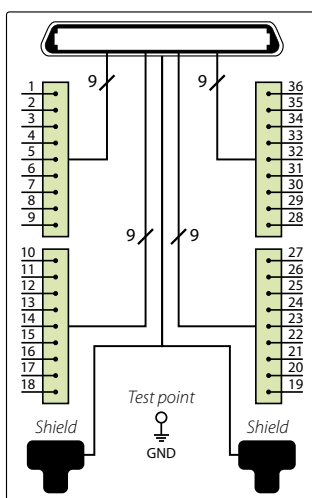
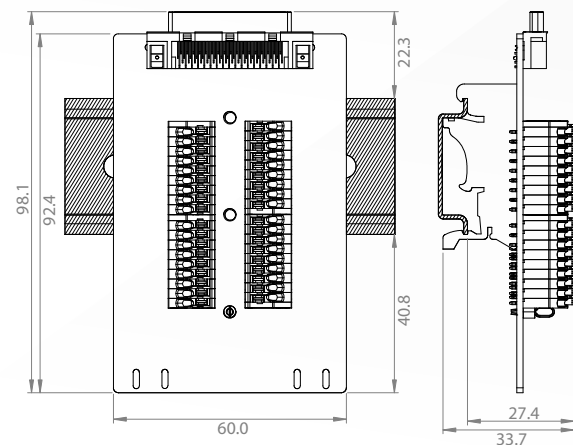

## SHIELDING AND CABLE RETENTION

The cable shield can be stripped and soldered to the conductive pad located under the cable path. This pad is connected to the RJ45's metallic shield, as shown in the schematic.

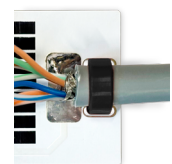

## KIT CONTENT

- 1x VHDCI breakout adapter
- 1x VHDCI-to-VHDCI shielded cable (1 m)
- 1x adhesive labels set

Parameter	Value
Connectivity	1x VHDCI (68-pin, female)
User Interface	68x push-in spring terminals
Wire Cross-section	0.2 to 0.5 mm <sup>2</sup>
Dimensions	60 x 98.1 x 33.7 mm

# VHDCI ADAPTER

## RCP-VHD

### ADHESIVE LABELS

The pinout of the VHDCI connectors is essentially cross-compatible among all imperix controllers. However, it isn't strictly identical. Specifically, the B-Box 4 supports an overlapping mapping between GPI and FLT inputs, as well as between GPO and PWM outputs. This mapping is configurable by software. It permits extending the I/O capabilities

of the B-Box 4 to 48 PWM outputs and 24 digital inputs. For this reason, VHDCI adapters are shipped with several adhesive labels specific to each controller type. These labels are meant to be placed on both sides of the terminal blocks, offering easier readability than the B-Box 4's multiplexed pinout for those who do not require it.

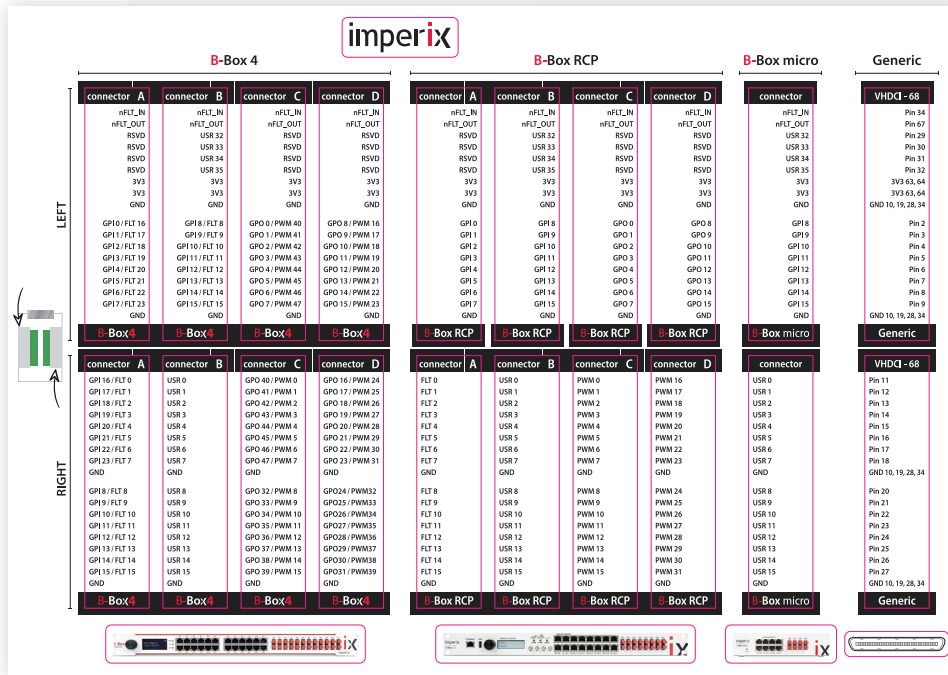

### GENERIC PINOUT

Pin	VHDCI - 68	Pin	VHDCI - 68
1	Pin 33	36	Pin 11
2	Pin 67	35	Pin 12
3	Pin 29	34	Pin 13
4	Pin 30	33	Pin 14
5	Pin 31	32	Pin 15
6	Pin 32	31	Pin 16
7	3V3 (63, 64)	30	Pin 17
8	3V3 (63, 64)	29	Pin 18
9	GND	28	GND
10	Pin 2	27	Pin 20
11	Pin 3	26	Pin 21
12	Pin 4	25	Pin 22
13	Pin 5	24	Pin 23
14	Pin 6	23	Pin 24
15	Pin 7	22	Pin 25
16	Pin 8	21	Pin 26
17	Pin 9	20	Pin 27
18	GND	19	GND

### B-BOX MICRO PINOUT

Pin	Connector	Pin	Connector
1	nFLT_IN	36	USR 0
2	nFLT_OUT	35	USR 1
3	USR 32	34	USR 2
4	USR 33	33	USR 3
5	USR 34	32	USR 4
6	USR 35	31	USR 5
7	3V3	30	USR 6
8	3V3	29	USR 7
9	GND	28	GND
10	GPI 8	27	USR 8
11	GPI 9	26	USR 9
12	GPI 10	25	USR 10
13	GPI 11	24	USR 11
14	GPI 12	23	USR 12
15	GPI 13	22	USR 13
16	GPI 14	21	USR 14
17	GPI 15	20	USR 15
18	GND	19	GND

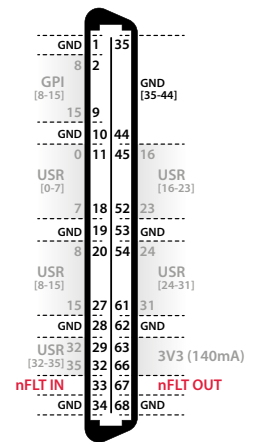
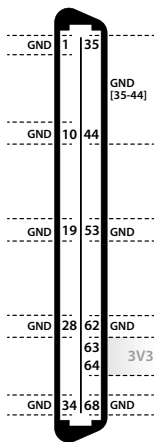

# VHDCI ADAPTER

RCP-VHD

## B-BOX 4 PINOUT

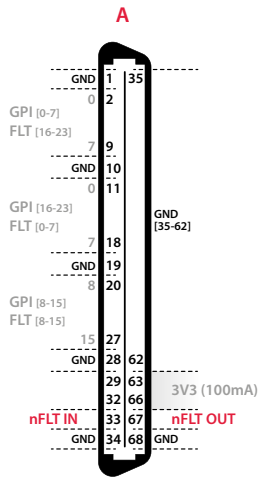

Pin	Connector A	Pin	Connector A	Pin	Connector B	Pin	Connector B
1	nFLT_IN	36	GPI 16/FLT 0	1	nFLT_IN	36	USR 0
2	nFLT_OUT	35	GPI 17/FLT 1	2	nFLT_OUT	35	USR 1
3	RSVD	34	GPI 18/FLT 2	3	USR 32	34	USR 2
4	RSVD	33	GPI 19/FLT 3	4	USR 33	33	USR 3
5	RSVD	32	GPI 20/FLT 4	5	USR 34	32	USR 4
6	RSVD	31	GPI 21/FLT 5	6	USR 35	31	USR 5
7	3V3	30	GPI 22/FLT 6	7	3V3	30	USR 6
8	3V3	29	GPI 23/FLT 7	8	3V3	29	USR 7
9	GND	28	GND	9	GND	28	GND
10	GPI 0/FLT 16	27	GPI 8/FLT 8	10	GPI 8/FLT 8	27	USR 8
11	GPI 1/FLT 17	26	GPI 9/FLT 9	11	GPI 9/FLT 9	26	USR 9
12	GPI 2/FLT 18	25	GPI 10/FLT 10	12	GPI 10/FLT 10	25	USR 10
13	GPI 3/FLT 19	24	GPI 11/FLT 11	13	GPI 11/FLT 11	24	USR 11
14	GPI 4/FLT 20	23	GPI 12/FLT 12	14	GPI 12/FLT 12	23	USR 12
15	GPI 5/FLT 21	22	GPI 13/FLT 13	15	GPI 13/FLT 13	22	USR 13
16	GPI 6/FLT 22	21	GPI 14/FLT 14	16	GPI 14/FLT 14	21	USR 14
17	GPI 7/FLT 23	20	GPI 15/FLT 15	17	GPI 15/FLT 15	20	USR 15
18	GND	19	GND	18	GND	19	GND

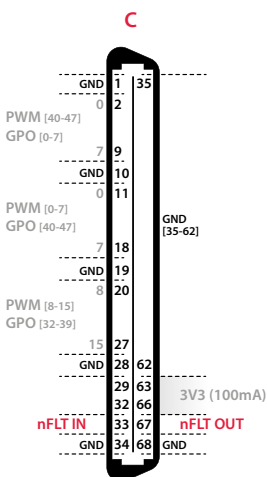
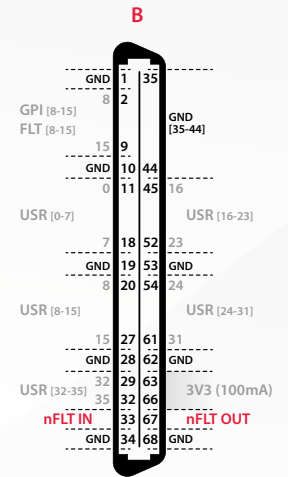

Pin	Connector C	Pin	Connector C	Pin	Connector D	Pin	Connector D
1	nFLT_IN	36	GPO 40/PWM 0	1	nFLT_IN	36	GPO 16/PWM 24
2	nFLT_OUT	35	GPO 41/PWM 1	2	nFLT_OUT	35	GPO 17/PWM 25
3	RSVD	34	GPO 42/PWM 2	3	RSVD	34	GPO 18/PWM 26
4	RSVD	33	GPO 43/PWM 3	4	RSVD	33	GPO 19/PWM 27
5	RSVD	32	GPO 44/PWM 4	5	RSVD	32	GPO 20/PWM 28
6	RSVD	31	GPO 45/PWM 5	6	RSVD	31	GPO 21/PWM 29
7	3V3	30	GPO 46/PWM 6	7	3V3	30	GPO 22/PWM 30
8	3V3	29	GPO 47/PWM 7	8	3V3	29	GPO 23/PWM 31
9	GND	28	GND	9	GND	28	GND
10	GPO 0/PWM 40	27	GPO 32/PWM 8	10	GPO 8/PWM 16	27	GPO 24/PWM 32
11	GPO 1/PWM 41	26	GPO 33/PWM 9	11	GPO 9/PWM 17	26	GPO 25/PWM 33
12	GPO 2/PWM 42	25	GPO 34/PWM 10	12	GPO 10/PWM 18	25	GPO 26/PWM 34
13	GPO 3/PWM 43	24	GPO 35/PWM 11	13	GPO 11/PWM 19	24	GPO 27/PWM 35
14	GPO 4/PWM 44	23	GPO 36/PWM 12	14	GPO 12/PWM 20	23	GPO 28/PWM 36
15	GPO 5/PWM 45	22	GPO 37/PWM 13	15	GPO 13/PWM 21	22	GPO 29/PWM 37
16	GPO 6/PWM 46	21	GPO 38/PWM 14	16	GPO 14/PWM 22	21	GPO 30/PWM 38
17	GPO 7/PWM 47	20	GPO 39/PWM 15	17	GPO 15/PWM 23	20	GPO 31/PWM 39
18	GND	19	GND	18	GND	19	GND

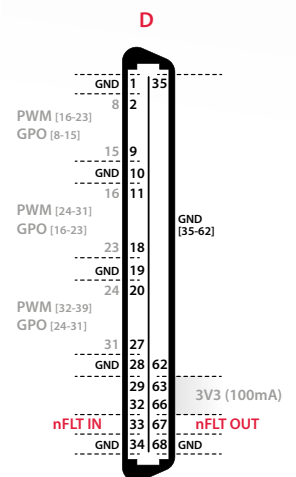

# VHDCI ADAPTER

RCP-VHD

## B-BOX 3 (RCP) PINOUT

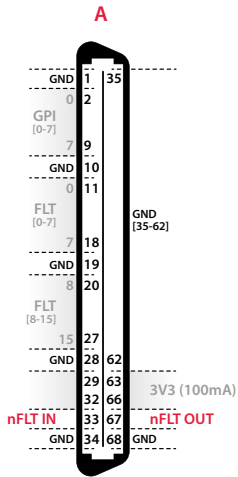

Pin	Connector A	Pin	Connector A	Pin	Connector B	Pin	Connector B
1	nFLT_IN	36	FLT 0	1	nFLT_IN	36	USR 0
2	nFLT_OUT	35	FLT 1	2	nFLT_OUT	35	USR 1
3	RSVD	34	FLT 2	3	USR 32	34	USR 2
4	RSVD	33	FLT 3	4	USR 33	33	USR 3
5	RSVD	32	FLT 4	5	USR 34	32	USR 4
6	RSVD	31	FLT 5	6	USR 35	31	USR 5
7	3V3	30	FLT 6	7	3V3	30	USR 6
8	3V3	29	FLT 7	8	3V3	29	USR 7
9	GND	28	GND	9	GND	28	GND
10	GPI 0	27	FLT 8	10	GPI 8	27	USR 8
11	GPI 1	26	FLT 9	11	GPI 9	26	USR 9
12	GPI 2	25	FLT 10	12	GPI 10	25	USR 10
13	GPI 3	24	FLT 11	13	GPI 11	24	USR 11
14	GPI 4	23	FLT 12	14	GPI 12	23	USR 12
15	GPI 5	22	FLT 13	15	GPI 13	22	USR 13
16	GPI 6	21	FLT 14	16	GPI 14	21	USR 14
17	GPI 7	20	FLT 15	17	GPI 15	20	USR 15
18	GND	19	GND	18	GND	19	GND

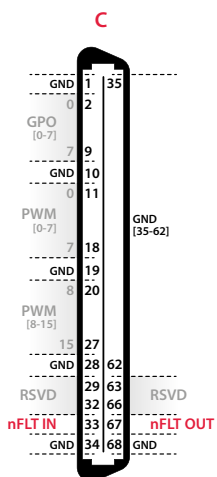
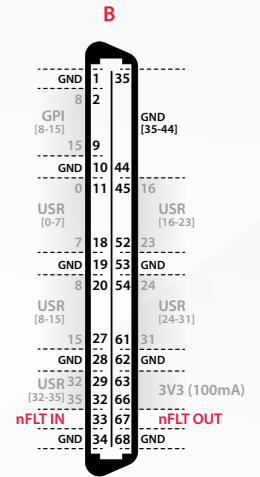

Pin	Connector C	Pin	Connector C	Pin	Connector D	Pin	Connector D
1	nFLT_IN	36	PWM 0	1	nFLT_IN	36	PWM 16
2	nFLT_OUT	35	PWM 1	2	nFLT_OUT	35	PWM 17
3	RSVD	34	PWM 2	3	RSVD	34	PWM 18
4	RSVD	33	PWM 3	4	RSVD	33	PWM 19
5	RSVD	32	PWM 4	5	RSVD	32	PWM 20
6	RSVD	31	PWM 5	6	RSVD	31	PWM 21
7	3V3	30	PWM 6	7	3V3	30	PWM 22
8	3V3	29	PWM 7	8	3V3	29	PWM 23
9	GND	28	GND	9	GND	28	GND
10	GPO 0	27	PWM 8	10	GPO 8	27	PWM 24
11	GPO 1	26	PWM 9	11	GPO 9	26	PWM 25
12	GPO 2	25	PWM 10	12	GPO 10	25	PWM 26
13	GPO 3	24	PWM 11	13	GPO 11	24	PWM 27
14	GPO 4	23	PWM 12	14	GPO 12	23	PWM 28
15	GPO 5	22	PWM 13	15	GPO 13	22	PWM 29
16	GPO 6	21	PWM 14	16	GPO 14	21	PWM 30
17	GPO 7	20	PWM 15	17	GPO 15	20	PWM 31
18	GND	19	GND	18	GND	19	GND

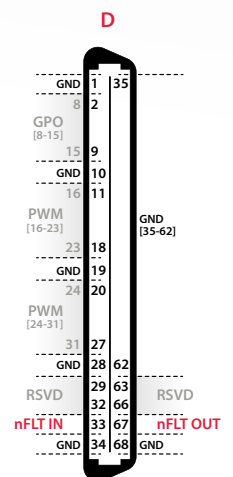

### CONTACT

imperix Ltd

Rte des Ronquos 23  
1950 Sion, Switzerland

### ABOUT US

Imperix develops high-end control equipment and prototyping hardware for power electronics, motor drives, smart grids and related topics. Our products are designed to accelerate the implementation of laboratory-scale power converters and facilitate the derivation of high-quality experimental results.

Copyright 2026. All rights reserved.