

# Power supply

**External 12V Power supply input**  
Min 10 Watt, 12VDC ±10%

The 5V power rail is actually driven at 5.2V by U11. This is intentional in order to:  
 \* supply the B-Board with the appropriate analog voltage (eg. supply of 5V000 reference)  
 \* improve behaviour of THS4551 opamps when common mode voltage is higher than 4.5V (which is unlikely)  
 Technically, it is possible to operate with a 5.0V power supply ; there are technical limitations as well as reduced compatibility with B-Box. Please contact support@imperix.ch to learn about the technical limitations before considering this option.

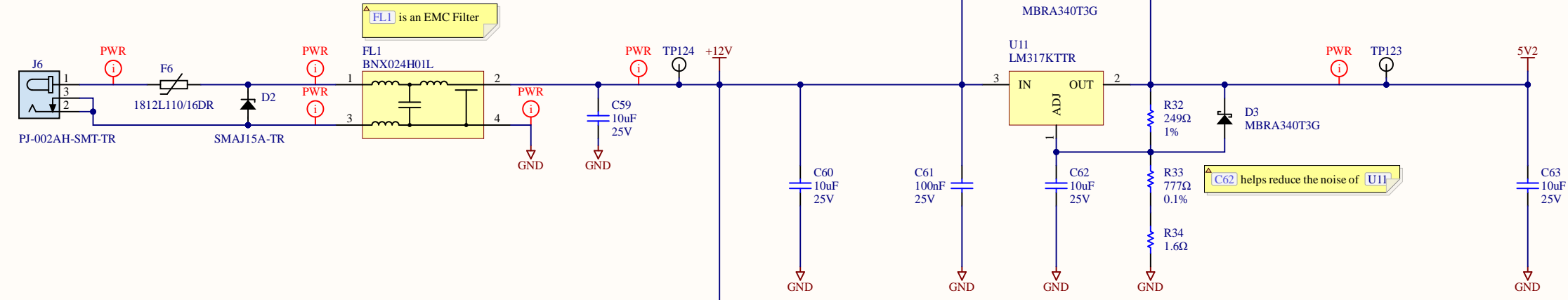

**5.2V Power supply**  
Max 200mA

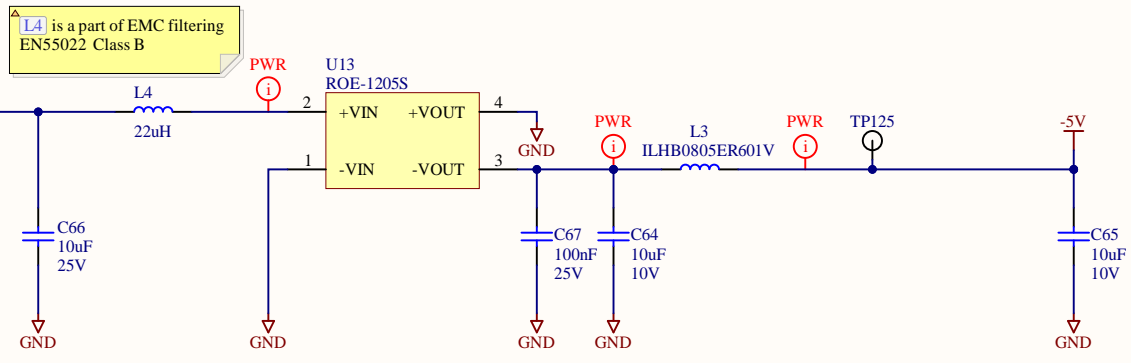
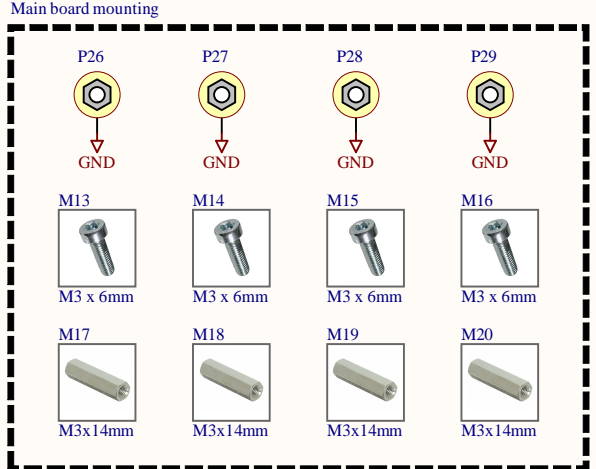
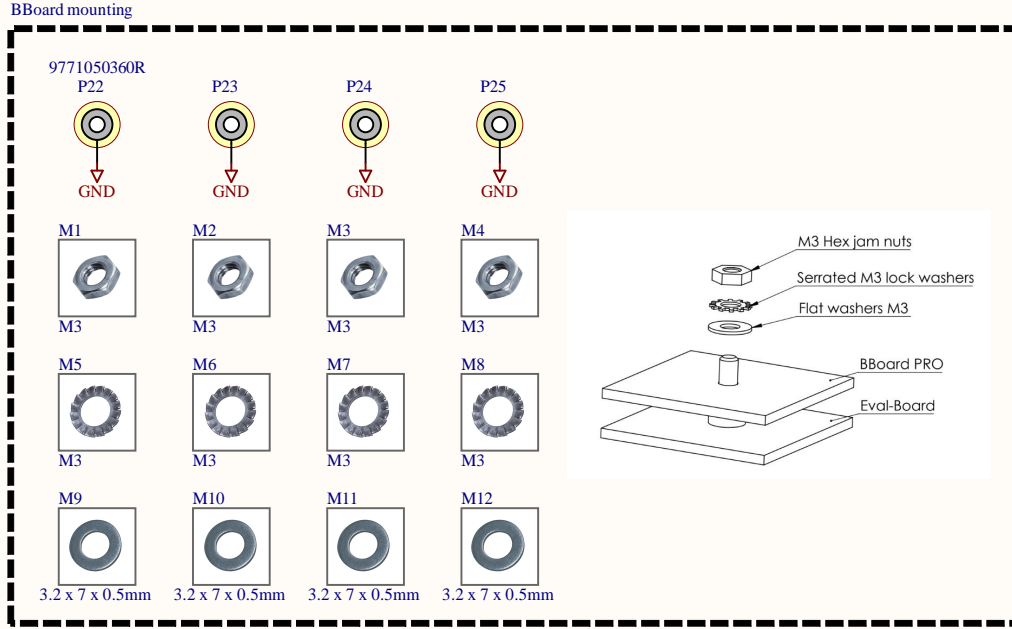

**-5V Power supply**  
Max 200mA

There are several versions of the U12 circuit. It is possible to choose another version depending on the applications (for example more current or variable voltage). The version currently used is: 1A, Auto mode, Spread spectrum, 2.2MHz, 3.3V fixed. You can easily find other configuration on: <https://webench.ti.com/power-designer/>

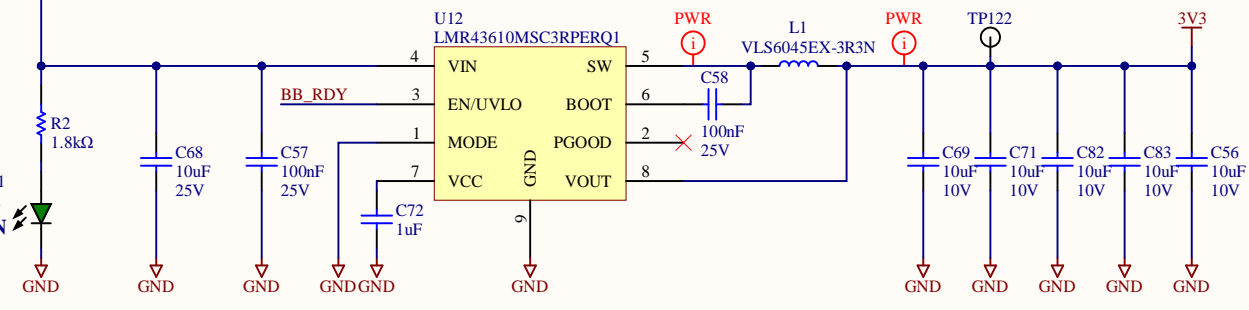
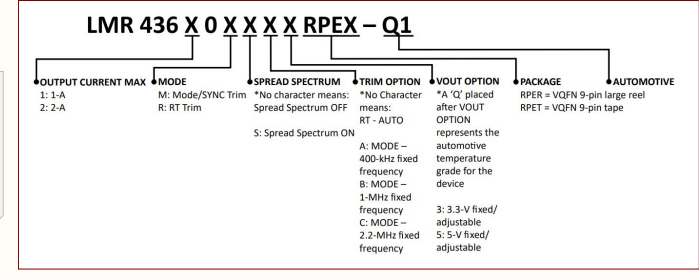

**3.3V Power supply**  
Max 1A

The BB\_RDY flag is used to trigger the activation of the 3.3V power supply. This way, no dangerous voltage can be applied to the Zynq during startup (e.g. through the CAN transceiver).

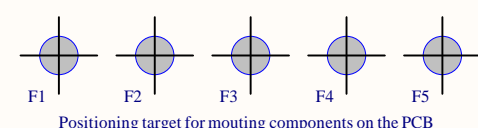

Title: Eval Board - Power supply			<p>Imperix Ltd Route des Rbnquos 23 1950 Son Switzerland +41 27 552 06 60 dev@imperix.ch</p>
Project: CB3-ECB.PrjPcb			
Size: A3	Date: 26/01/2024 Time: 15:17:54	Revision: C1	
Author: O. Guinnard	Revised by: Nicolas Cherix	Sheet 1 of 6 File: C:\Users\Public\Documents\Altium\CB3-ECB\Power.SchDoc	

# Analog outputs

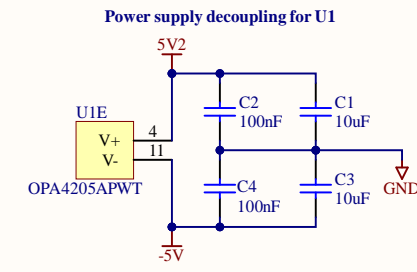

$$A_{out} = \frac{R5}{R6} * (Vref - Vin) = 2 * (Vref - Vin)$$

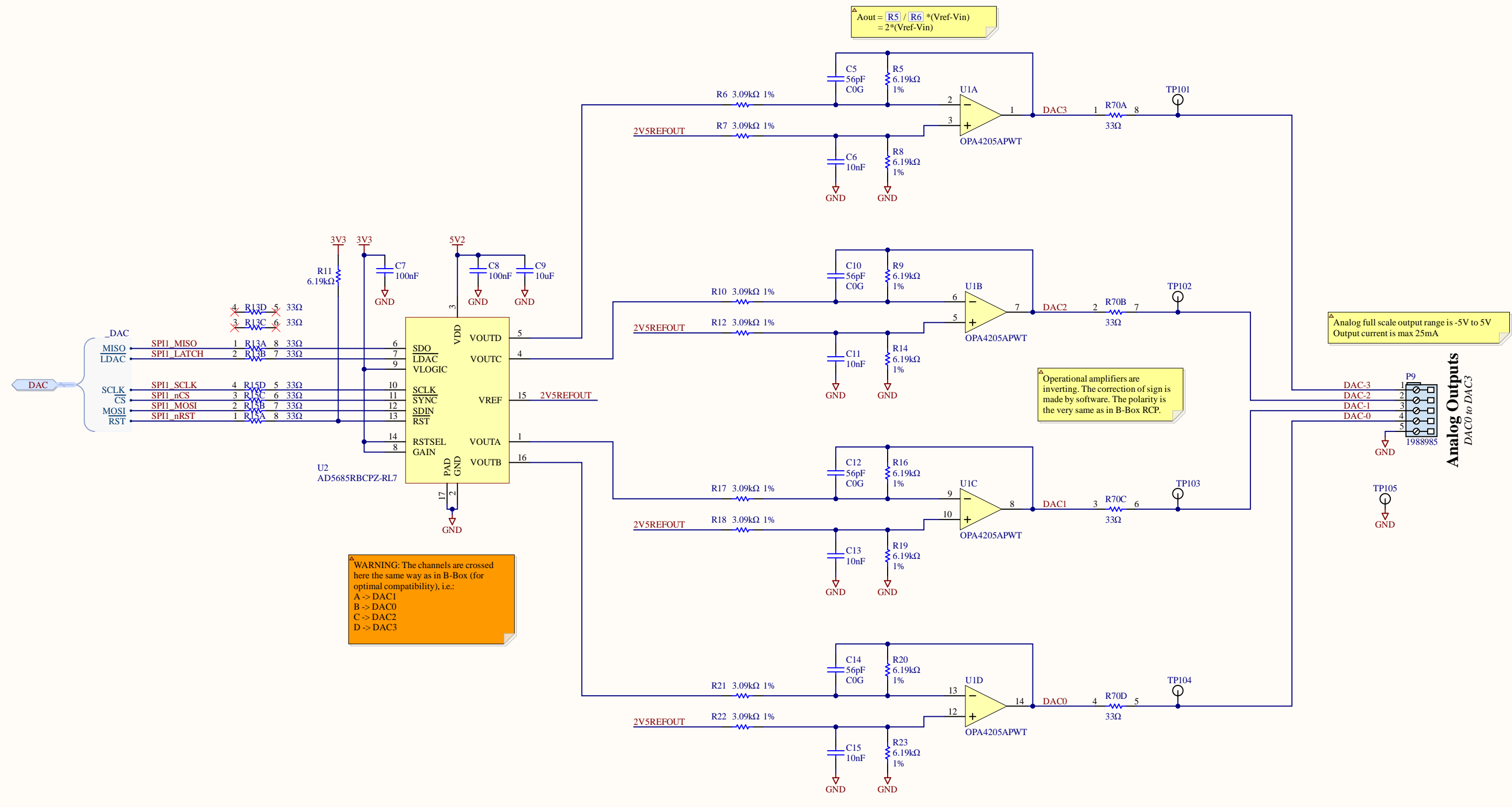

Analog full scale output range is -5V to 5V  
Output current is max 25mA

Operational amplifiers are inverting. The correction of sign is made by software. The polarity is the very same as in B-Box RCP.

**WARNING:** The channels are crossed here the same way as in B-Box (for optimal compatibility), i.e.:  
A -> DAC1  
B -> DAC0  
C -> DAC2  
D -> DAC3

Analog Outputs  
DAC0 to DAC3

Title: Eval Board - Analog outputs				Imperix Ltd Route des Ronquos 23 1950 Son Switzerland +41 27 552 06 60 dev@imperix.ch
Project: CB3-ECB.PrjPcb				
Size: A3	Date: 26/01/2024 Time: 15:17:54	Revision: C1	Sheet 2 of 6	
Author: O. Guinnard	Revised by: Nicolas Cherix		File: C:\Users\Public\Documents\Altium\CB3-ECB.DAC.SchDoc	

# Analog differential inputs

The input range is 0 to 5V for all signals ( $V_{P\_and\_N}$ ). This is why, in differential mode, the range is  $\pm 5V$ .

1M $\Omega$  input resistors are not necessary in most applications. On this evaluation board, these resistors allow the inputs to be polarized when there is no connection to the analog inputs.

Resistor networks allow superior gain accuracy of the driver stage.

User can implement lower resistors values, such as 1k $\Omega$  instead of 10k $\Omega$ . This reduces noise but also reduces the impedance of the analog inputs.

Full-differential amplifiers are used for larger common-mode input voltage range and lower total input offset voltage.

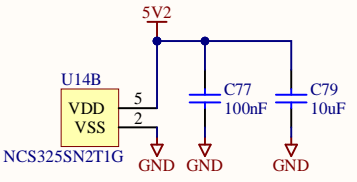
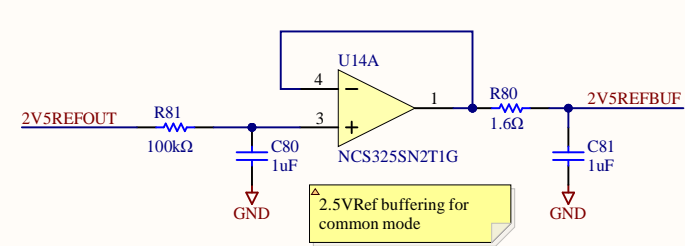
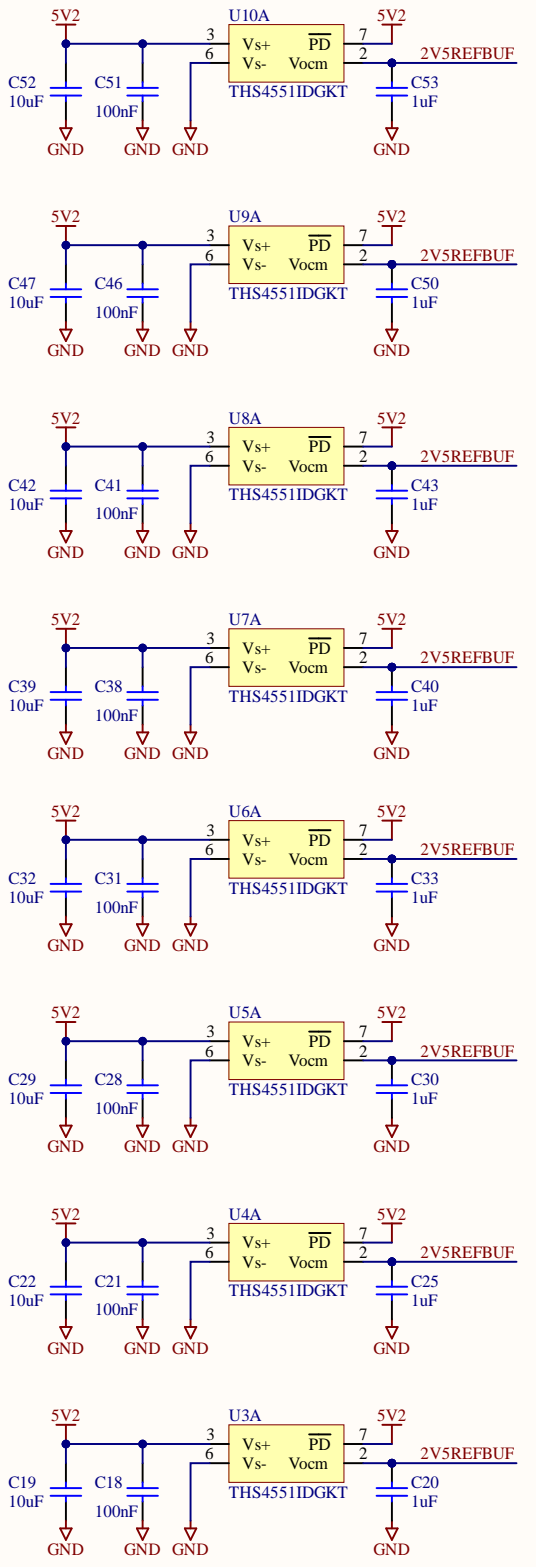
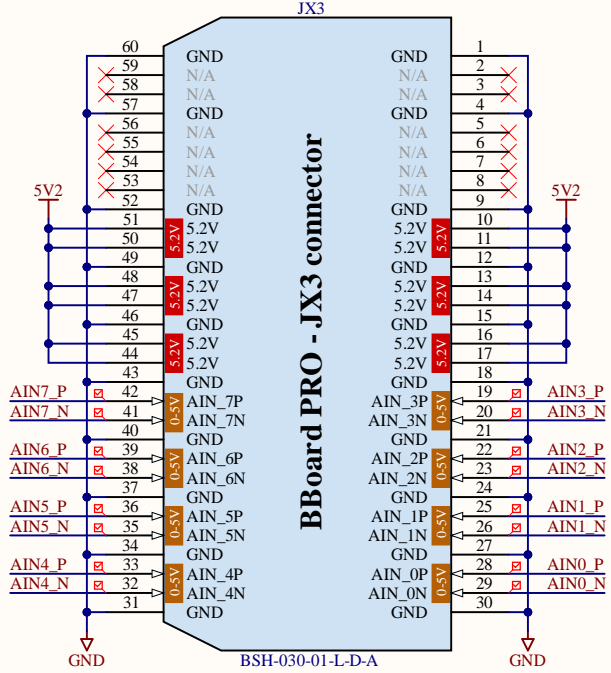
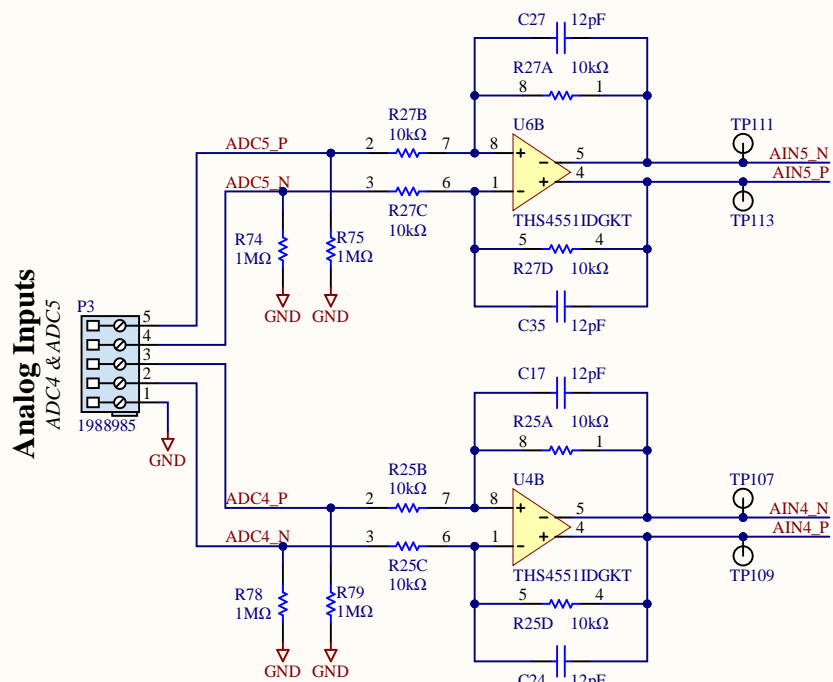
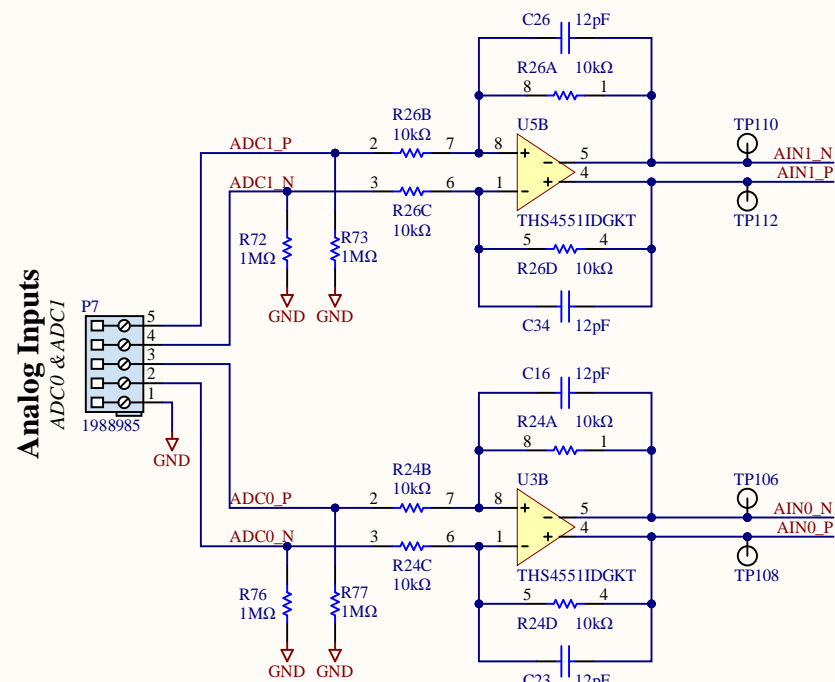
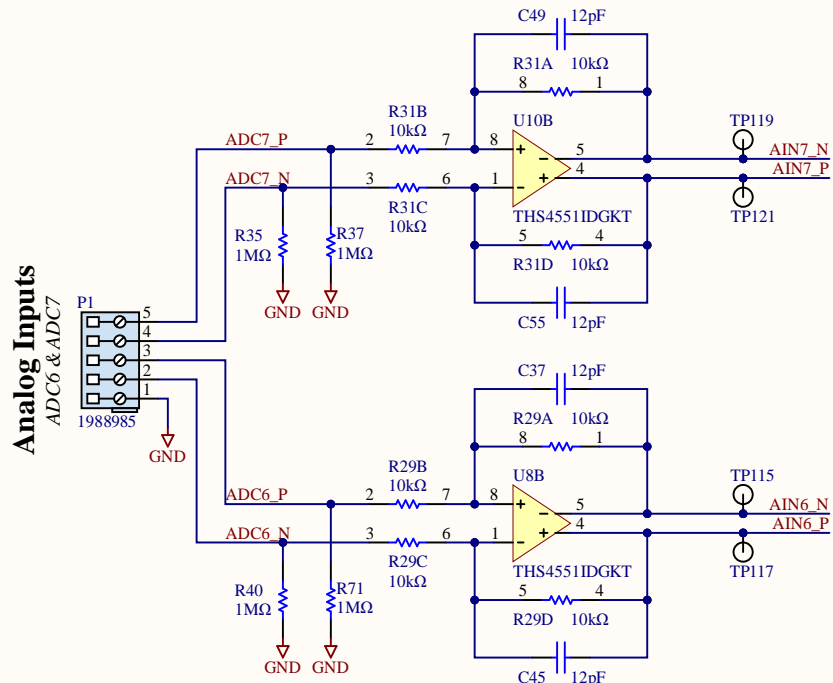
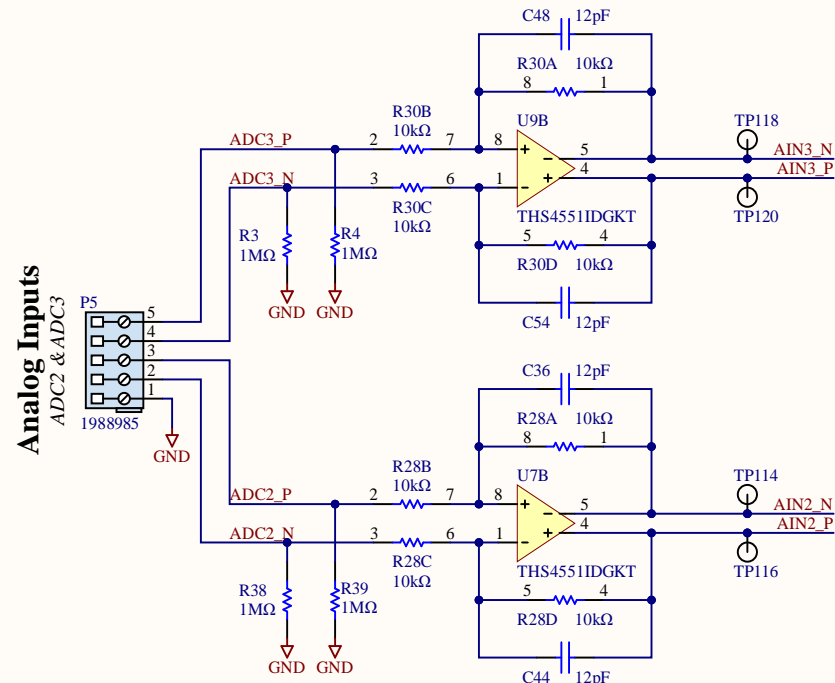

Title: Eval Board - Analog differential inputs				Imperix Ltd Route des Ronquos 23 1950 Son Switzerland +41 27 552 06 60 dev@imperix.ch
Project: CB3-ECB.PrjPcb				
Size: A3	Date: 26/01/2024 Time: 15:17:54	Revision: C1		
Author: O. Guinnard	Sheet 3 of 6			
Revised by: Nicolas Cherix		File: C:\Users\Public\Documents\Altium\CB3-ECB.ADC.SchDoc		

# Ethernet and CAN interface

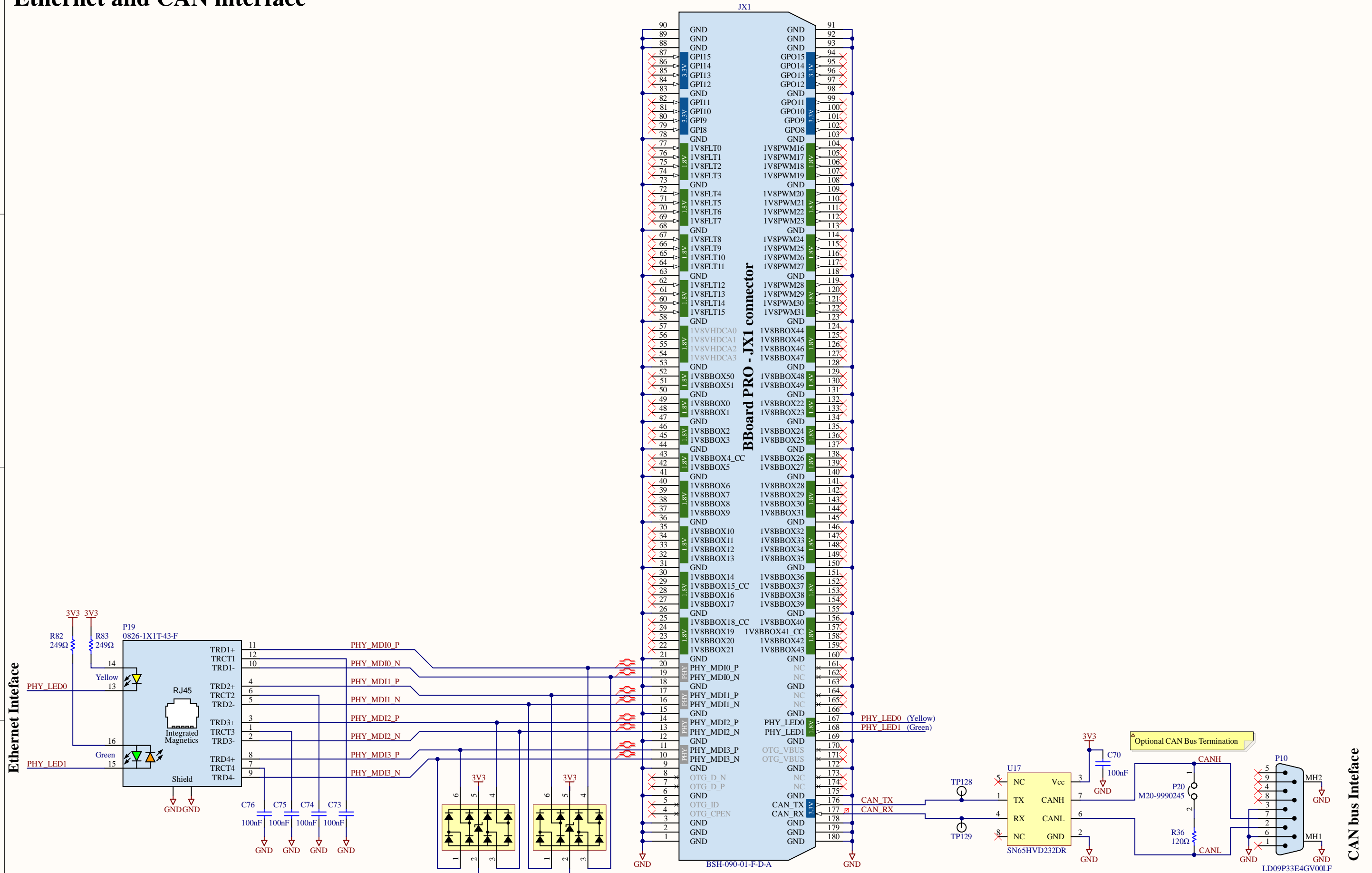

Title: Eval Board - BBoard JX1 connector (Ethernet , CAN bus)				<p>Imperix Ltd Route des Ronquos 23 1950 Son Switzerland +41 27 552 06 60 dev@imperix.ch</p>
Project: CB3-ECB.PrjPcb				
Size: A3	Date: 26/01/2024 Time: 15:17:54	Revision: C1	Sheet 4 of 6	
Author: O. Guinnard	Revised by: Nicolas Cherix		File: C:\Users\Public\Documents\Altium\CB3-ECB\BBoard-JX1.SchDoc	

# Digital I/O

All inputs/outputs are 3.3V

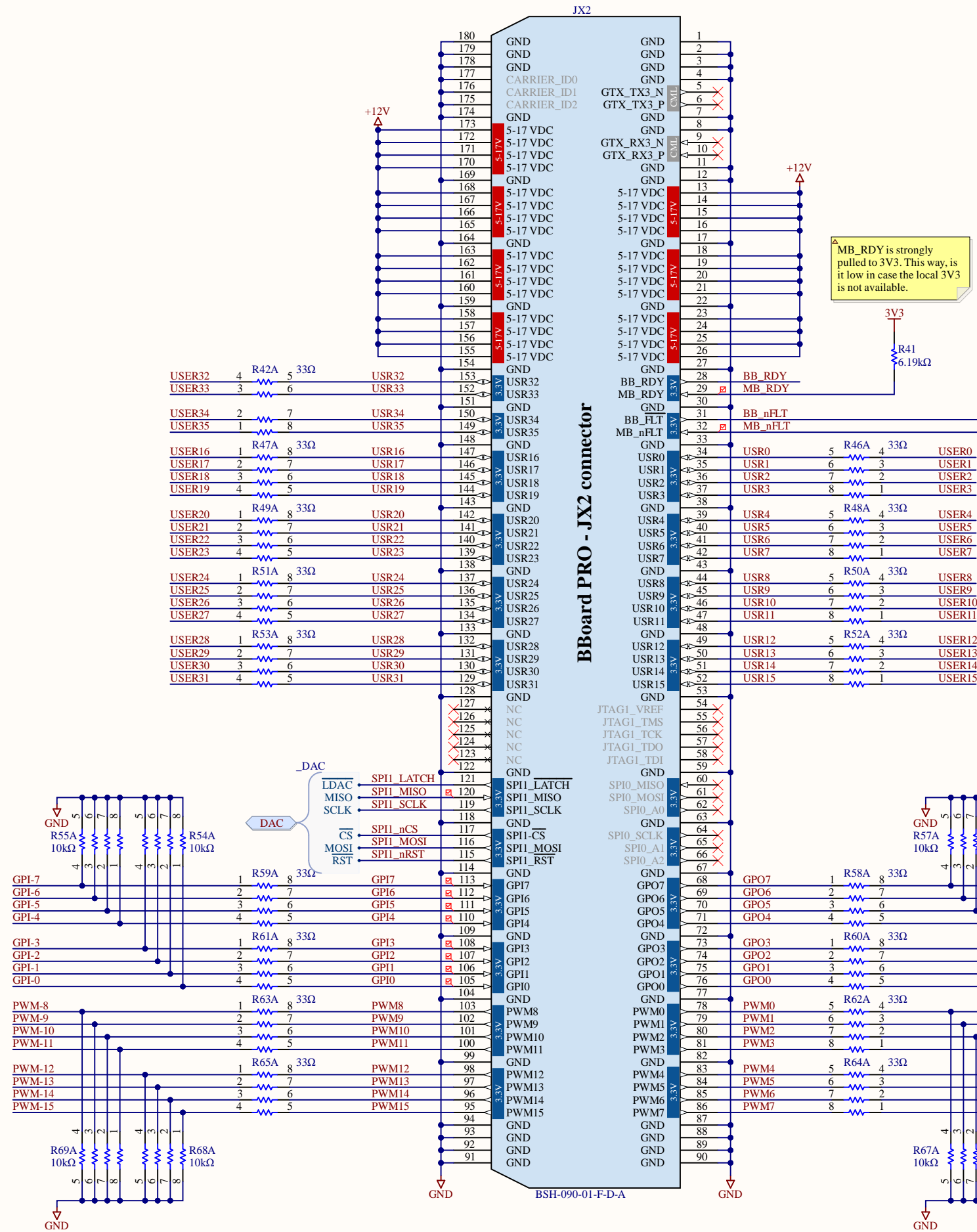
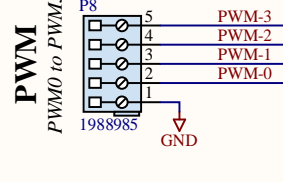
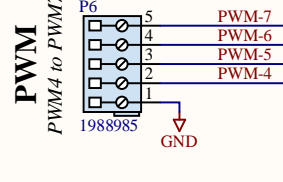
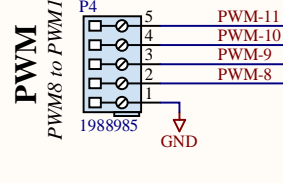
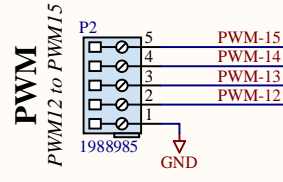
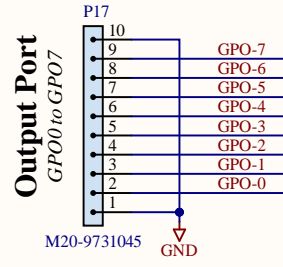
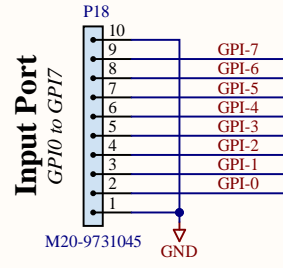

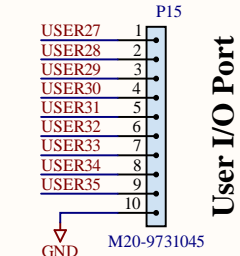
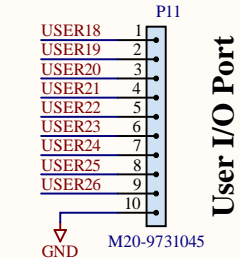
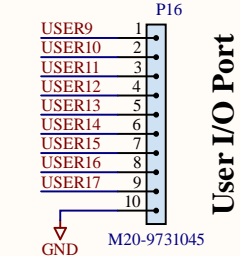
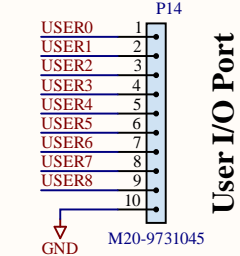
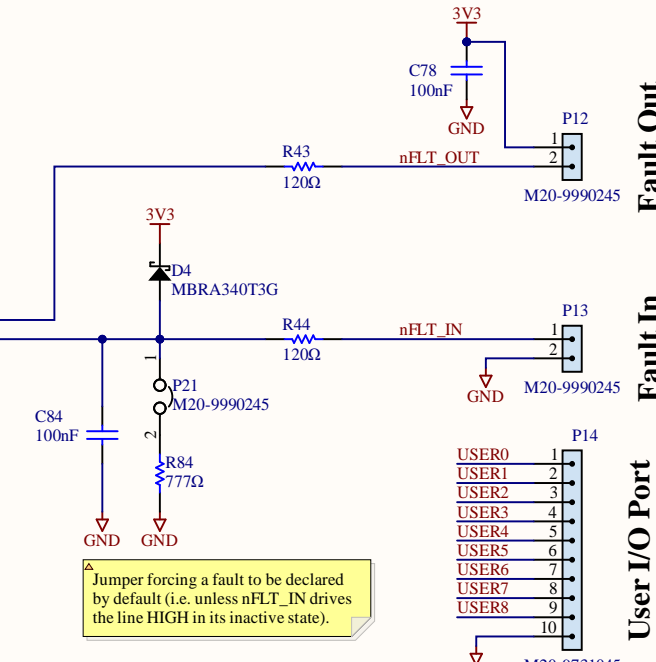

MB\_RDY is strongly pulled to 3V3. This way, is it low in case the local 3V3 is not available.

Jumper forcing a fault to be declared by default (i.e. unless nFLT\_IN drives the line HIGH in its inactive state).

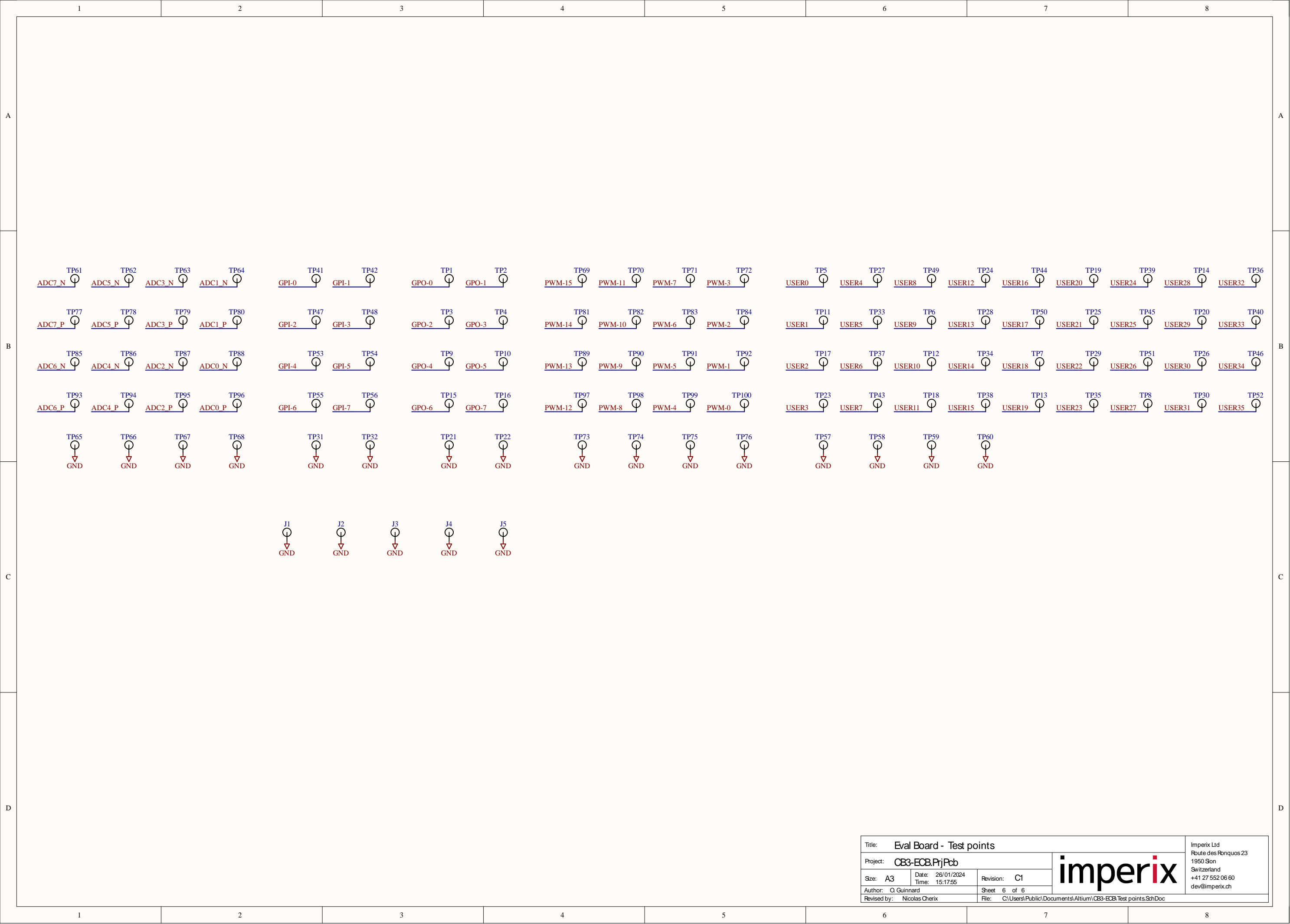

Title: Eval Board - BBoard JX1 connector (PWM, GPIO)		imperix	Imperix Ltd Route des Ronquos 23 1950 Son Switzerland +41 27 552 06 60 dev@imperix.ch
Project: CB3-ECB.PrjPcb	Date: 26/01/2024 Time: 15:17:55		
Size: A3	Revision: C1	Sheet 5 of 6	
Author: O. Guinnard	Revised by: Nicolas Cherix	File: C:\Users\Public\Documents\Altium\CB3-ECB\BBoard-JX2.SchDoc	



Title: Eval Board - Test points				Imperix Ltd Route des Ronquos 23 1950 Son Switzerland +41 27 552 06 60 dev@imperix.ch
Project: CB3-ECB.PrjPcb		Revision: C1		
Size: A3	Date: 26/01/2024 Time: 15:17:55	Sheet 6 of 6		
Author: O. Guinnard		File: C:\Users\Public\Documents\Altium\CB3-ECB\Test points.SchDoc		
Revised by: Nicolas Cherix				