



VSR-1000-ISO

±1000V ISOLATED HIGH-VOLTAGE SENSOR

HIGH-PERFORMANCE SOLUTIONS FOR
CONTROL DEVELOPMENT AND TESTING



VSR-1000-ISO

±1000V ISOLATED HIGH-VOLTAGE SENSOR

“ A sensor offering versatility across applications, thanks to its broad input range and robust safety features

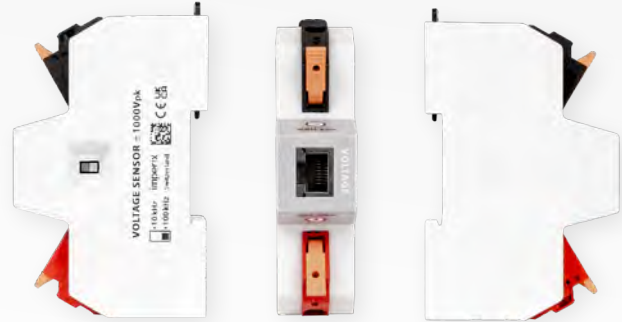

GENERAL DESCRIPTION

The VSR-1000-ISO is a high-voltage isolated sensor suited for measurements in power conversion systems. Its flexibility allows its use across a variety of applications and setups.

Equipped with a special common-mode compensation circuit, this sensor offers excellent common-mode rejection across a broad frequency range. This ensures reliable operation even under challenging conditions.

The device features 1500V_{RMS} galvanic isolation, compatible with reinforced isolation between the power and control circuits for numerous applications.

This sensor converts a ±1000V input into a ±5V output, reflecting its 5mV/V sensitivity. Input connections are conveniently accessible via laboratory banana plugs or direct wiring, while the output is delivered as a differential signal on the RJ45 connector.

The VSR-1000-ISO is optimized for seamless integration with imperix controllers, which supply the required ±15V power through the RJ45 connector. It can also be used with other data acquisition systems, ensuring the correct pinout is followed.

KEY FEATURES AND SPECIFICATIONS

- Auto-configuration with B-Box 4 (1-wire link)
- ±1000V_{pk} measurement range
- 1500V_{RMS} galvanic isolation (basic)
- Excellent CMRR over wide frequency range
- Selectable bandwidth (100kHz or 10kHz)
- ±330mV offset (typ.) – factory calibration available on B-Box 4
- ±0.3% gain error (typ.) – factory calibration available on B-Box 4
- Self-powered from imperix controllers (±15V)

TYPICAL APPLICATIONS

- High-performance current control (bandwidth, precision)
- Monitoring, scoping, debug
- System identification

BENEFITS

The ±1000V input range makes the sensor highly versatile, covering a broad range of use cases from high-voltage DC applications to AC mains. Its strong common-mode voltage rejection ensures that measurements remain accurate, even when large common-mode voltages or significant electrical noise are present in the system. In addition, it guarantees a high level of safety thanks to the built-in galvanic isolation.

DIN-rail mounting allows for straightforward integration into test benches or cabinets. It also provides convenient input connectivity, offering both laboratory banana plugs and wire terminals for direct wiring. The sensor integrates effortlessly with imperix controllers in a plug-&-play manner, with the RJ45 interface transmitting power supplies, measurement signals, and calibration information.

SIMPLIFIED SCHEMATIC

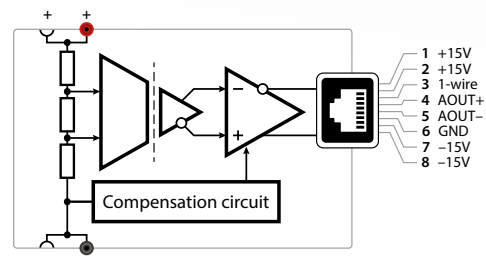

RELATED PRODUCTS

Sensor	Type	Range	BW	CMTI	Production
VSR-500-HBW	Differential	±500V _{pk}	3 MHz	very high	Active
VSR-1000-ISO	Isolated	±1000V _{pk}	100 kHz	very high	Active
CSR-25-HBW	Isolated	±25A _{RMS}	1.5 MHz	very high	Active
DIN-800V	Isolated	±800V _{pk}	100 kHz	medium	NRND
DIN-50A	Isolated	±50A _{pk}	200 kHz	medium	NRND

TECHNICAL SPECIFICATIONS

ABSOLUTE MAXIMUM RATINGS

Parameter	Symbol	Test conditions	Min.	Typ.	Max.	Unit
Maximum tolerable input voltage		IN+ to IN-	-	3.0	-	kV _{pk}
		IN+ or IN- to GND	-	1.5	-	kV _{RMS}
ESD Human Body Model			-	±2	-	kV
Power supply voltage	±V _{CC}		±12	±15	±18	V

INSULATION CHARACTERISTICS

Parameter	Symbol	Test conditions	Min.	Typ.	Max.	Unit	
Maximum repetitive peak isolation voltage	V _{IORM}	AC voltage	-	2120	-	V _{pk}	
Maximum-rated isolation working voltage	V _{IOWM}	AC voltage	OVCII, PD2, basic isolation	-	1500	-	V _{RMS}
			OVCII, PD2, reinforced isolation	-	750	-	V _{RMS}
		DC voltage	OVCII, PD2, basic isolation	-	2120	-	V _{DC}
			OVCII, PD2, reinforced isolation	-	1060	-	V _{DC}

ELECTRICAL CHARACTERISTICS

Parameter	Symbol	Test conditions	Min.	Typ.	Max.	Unit
Nominal input voltage, linear range	V _{NOM}		-	±1000	-	V _{pk}
Maximum measurable voltage	V _{MAX}		-	±1380	-	V _{pk}
Nominal sensitivity	G	Load resistance R _L = 5 kΩ	-	5.0	-	mV/V
Sensitivity error	G _E	Disregarding calibration data	-	-	±0.2	%
Input-referred offset	V _O	Disregarding calibration data	-	±150	±450	mV
	V _{O, BB4}	On B-Box 4 with calibration data enabled	-	±25	±75	mV
Response time	t _{resp}	To 90% of final value	-	6.45	-	μs
Measurement bandwidth	f _{3dB, High}	Selector set to HIGH bandwidth	-	100	-	kHz
	f _{3dB, Low}	Selector set to LOW bandwidth	-	10	-	kHz
Input-referred noise, RMS	V _{N, high}	100 Hz - 100 kHz	-	590	-	mV
	V _{N, low}	100 Hz - 10 kHz	-	220	-	mV
Input series resistance	R _{IN}		-	6.5	-	MΩ
Output impedance, differential	R _{OUT}		19.8	20.0	20.2	Ω
Output short-circuit current	I _{SC}			±37		mA
Power consumption	P _{DD}		-	0.68	-	W

OFFSET

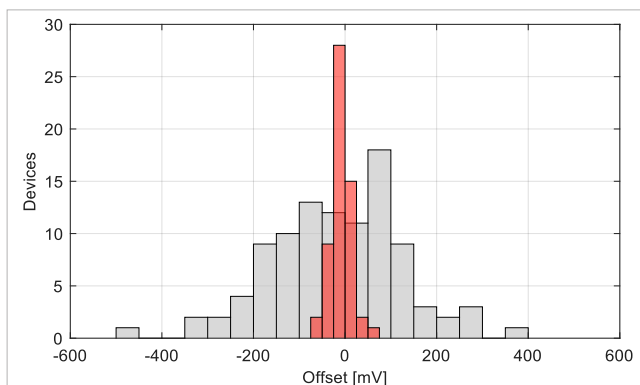

Fig. 1. Statistical distribution of input-referred offset (grey: uncalibrated, red: calibrated).

SENSITIVITY ERROR

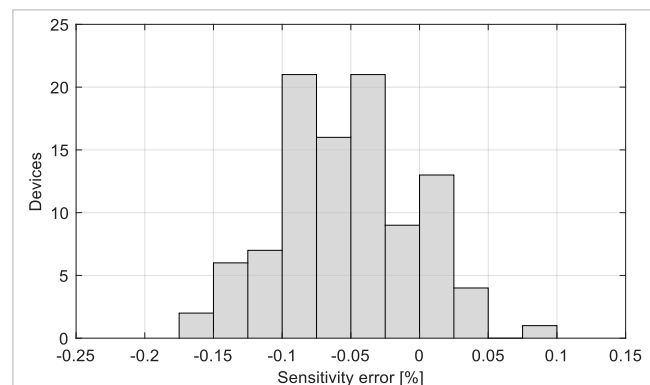

Fig. 2. Statistical distribution of sensitivity error (uncalibrated).

TYPICAL CHARACTERISTICS

LARGE SIGNAL STEP RESPONSE

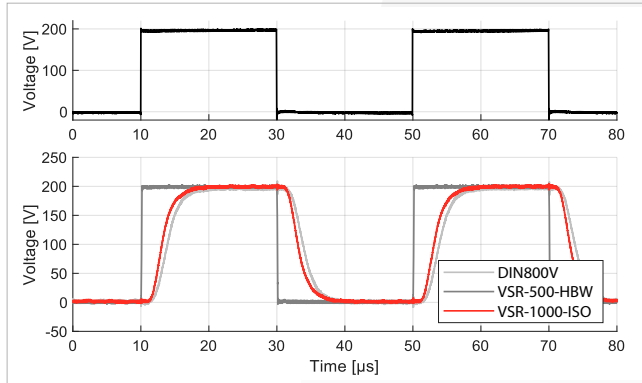

Fig. 3. Comparing VSR-1000-ISO with other imperix voltage sensors.

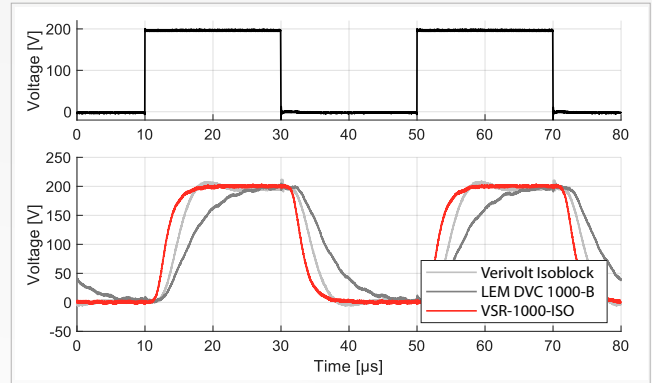

Fig. 4. Comparing VSR-1000-ISO with competing solutions.

COMMON-MODE VOLTAGE REJECTION

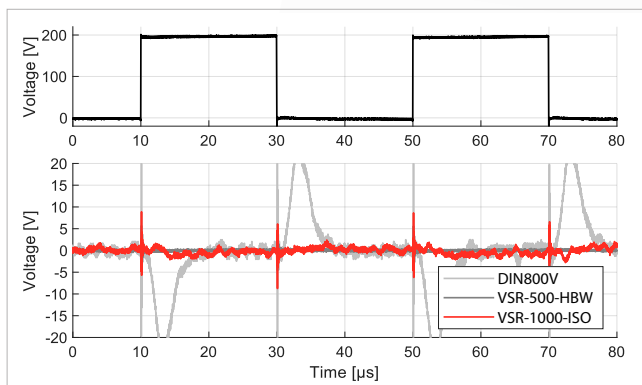

Fig. 5. Comparing VSR-1000-ISO with other imperix voltage sensors.

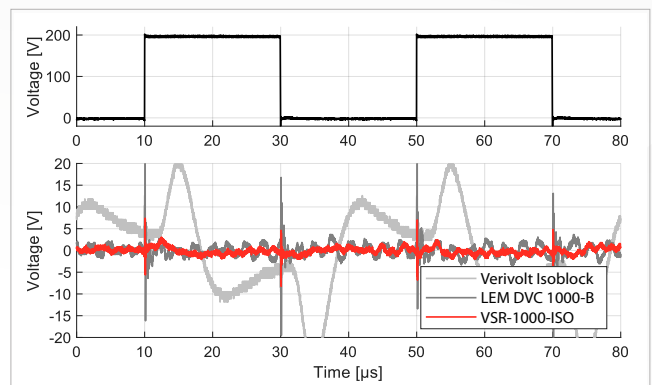

Fig. 6. Comparing VSR-1000-ISO with competing solutions.

FREQUENCY RESPONSE

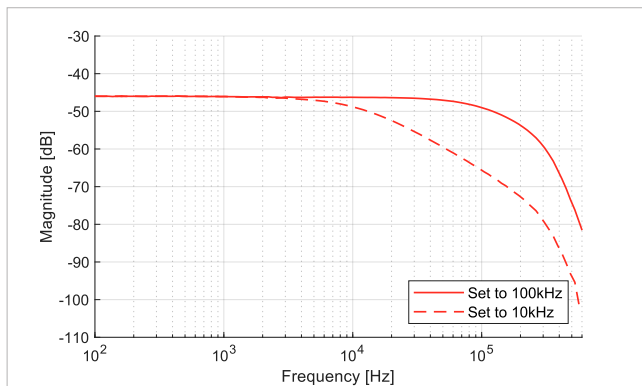

Fig. 7. Differential mode transfer function.

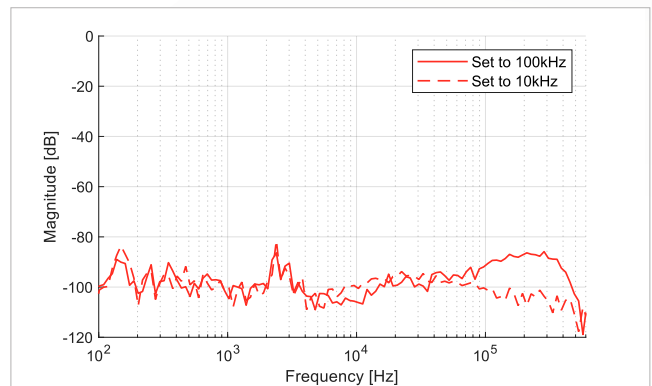

Fig. 8. Differential to common-mode transfer function.

NOISE

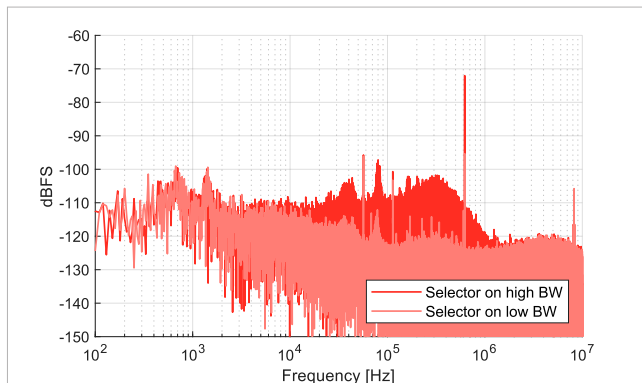

Fig. 9. Noise spectrum of the sensor, measured with B-Box 4

MECHANICAL SPECIFICATIONS

DIMENSIONS

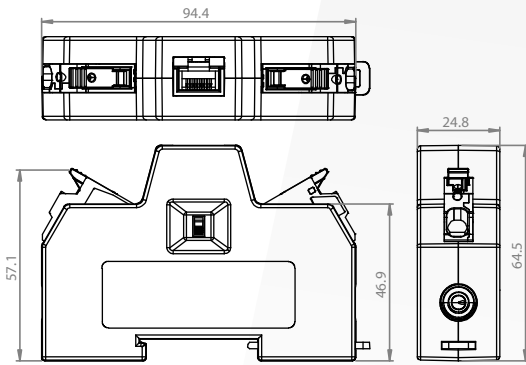

Fig. 10. Dimensions of the VSR-1000-ISO sensors.

AUTO-IDENTIFICATION AND CALIBRATION

The VSR-1000-ISO sensors embeds an EEPROM, which contains information on the sensor type as well as its calibration parameters. This data can be read from B-Box 4 and enable the auto-identification. The EEPROM is accessible over a 1-wire communication link present on pin 3 of the RJ45 connector.

FACTORY PARAMETERS

The following table lists the stored parameters. During factory testing, the offset is calibrated; however, the sensitivity is not calibrated.

Parameter	Value	User access from B-Box 4
Sensor type	VSR-1000-ISO	Read only
Nominal sensitivity	0.005 [V/V]	Read only
Calibrated sensitivity	0.005 [V/V]	Read / write
Calibrated offset	0 [V]	Read / write

Table 1. Information stored in the EEPROM

CALIBRATION PROCEDURE

If the user wishes to update the calibration data present inside the EEPROM, this can be done by clicking the "edit" button in Cockpit:

- Switch from the "Projects" view to the "Targets" view.
- Select the correct target (if not already the case).
- Navigate to the "Analog I/Os" configuration tab.
- Select the correct channel.
- Click on the "edit" button, as shown in Fig. 13.

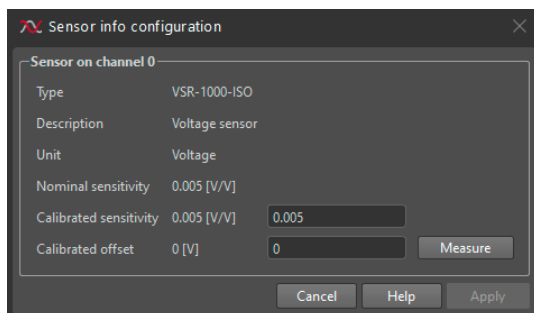

Fig. 11. Editing the calibration data in imperix Cockpit.

MOUNTING INSTRUCTIONS

VRS-1000-ISO sensors are designed to be mounted on 35mm DIN rails. To correctly mount the device:

- Pull the black spring-type locker out.
- Place the sensor on the rail.
- Push back the spring-type locker.

WIRING INSTRUCTIONS

Beware of the limited current-carrying capacity of the 4 mm (banana) connectors. Their rating (24A) is similar to that of most laboratory cables. For higher-current applications, use the wire terminals.

Do not use wire sleeves with the wire terminals. Their internal surfaces are flat, preventing any risk of damage to stranded wires.

DISABLING CALIBRATION INFORMATION

By default, the B-Box 4 uses calibration parameters in order to improve the accuracy of the retrieved measurement. If, for any reason, the user wishes to bypass this behaviour, calibration can be disabled in the analog I/O configuration of the B-Box 4:

- Directly on B-Box 4, select the "analog I/O" configuration menu. Select the desired channel, and then "disable" in the relevant screen:

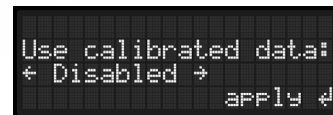

Fig. 12. Status message on the OLED screen of the B-Box 4.

- In Cockpit, uncheck the "USE CALIBRATION DATA" checkbox in the "analog I/O" tab of the "target" configuration.

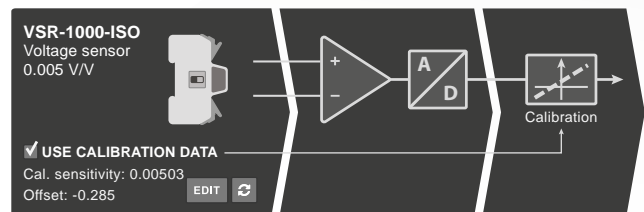

Fig. 13. Relevant section of the "analog I/O" configuration in Cockpit.

RELATED DOCUMENTATION

PRINT

- Datasheet of the B-Box 4 – [link](#)

ONLINE

- Sensor auto-identification on B-Box 4 – [link](#)
- Analog I/O configuration on B-Box 4 – [link](#)
- Architecture and operation of B-Box 4 – [link](#)
- Over-current and over-voltage protection – [link](#)
- Advanced sampling techniques – [link](#)

ENVIRONMENTAL CONDITIONS

Parameter	Value
System voltage	300V, OVC II, PD2
Operating conditions (IEC/EN 60721-3-3)	Climate conditions for operation class 3K3: – Temperature range: 0°C to +40°C – Relative humidity: < 95%, no condensation – Atmospheric pressure: 70KPa to 106KPa
Storage conditions (IEC/EN 60721-3-1)	Climate conditions for storage class 1K3: – Temperature range: -25°C to +55°C – Relative humidity: < 95%, no condensation – Atmospheric pressure: 70KPa to 106KPa
IP rating	IP 20
Protection class	Class II

Table 2. Rated environmental conditions

PINOUT

Pin	Pair	Color	Description
1	2	orange stripe	+15 V
2	2	orange solid	+15 V
3	3	green stripe	1-WIRE data
4	1	blue solid	Positive input / current input
5	1	blue stripe	Negative input / ground
6	3	green solid	GND
7	4	brown stripe	-15 V
8	4	brown solid	-15 V

Table 3. Pinout of the RJ45 connector.

REVISION HISTORY

- **26.09.25**: Preliminary version
- **10.03.26**: Added statistics on offset and sensitivity error.

CONTACT

imperix Ltd

Rte des Ronquos 23
1950 Sion, Switzerland
www.imperix.com
support@imperix.com

ABOUT US

Imperix develops high-end control equipment and prototyping hardware for power electronics, motor drives, smart grids, and related applications. Our products are designed to accelerate the implementation of laboratory-scale power converters and facilitate the acquisition of high-quality experimental results.

NOTE

While every effort has been made to ensure accuracy in this publication, no responsibility can be accepted for errors or omissions. This publication is not intended to form the basis of a contract.

Copyright 2026. All rights reserved.

